

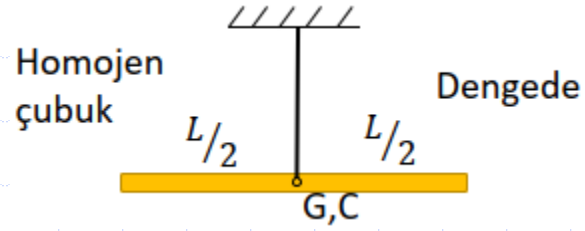

# *BÖLÜM 5*

## AĞIRLIK MERKEZİ



**G:** Ağırlık Merkezi  
**C:** Geometrik merkez

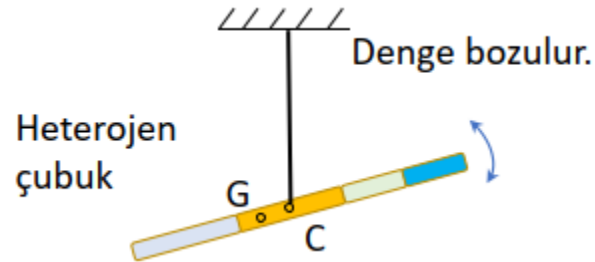
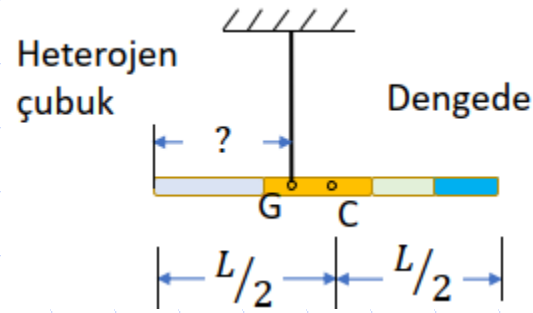

Geometrisi daha karmaşık olan cisimlerde bu merkezlerin yerlerinin belirlenmesi daha fazla işlem gerektirecektir. Serbest cisim diyagramlarının doğru çizebilmek için **ağırlık kuvvetinin hangi noktaya yerleştirileceğinin** bilmemiz şarttır. Bu ise ağırlık merkezi hesaplamalarının önemini ortaya koyar.

Çizgisel, alansal ve hacimsel cisimlerin ağırlık merkezleri aynı yöntemle hesaplanabilmektedir. Alanların ağırlık merkezinin hesaplanması, bazı mukavemet hesaplarına bir hazırlık teşkil etmektedir.

Biz bu bölümde incelenen cisimleri **homojen** kabul ederek, geometrik ve ağırlık merkezinin çakıştığını düşüneceğiz ve daha çok **düzlemsel alanların** ağırlık merkezinin hesaplamaları üzerinde duracağız.

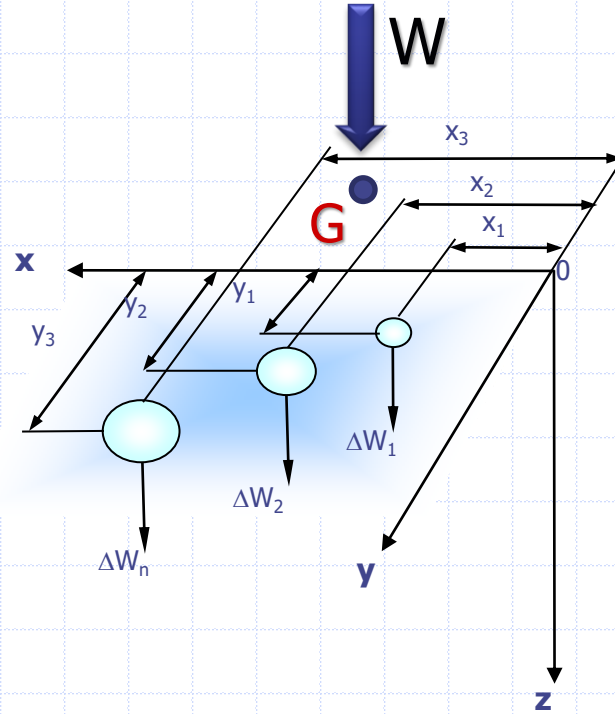
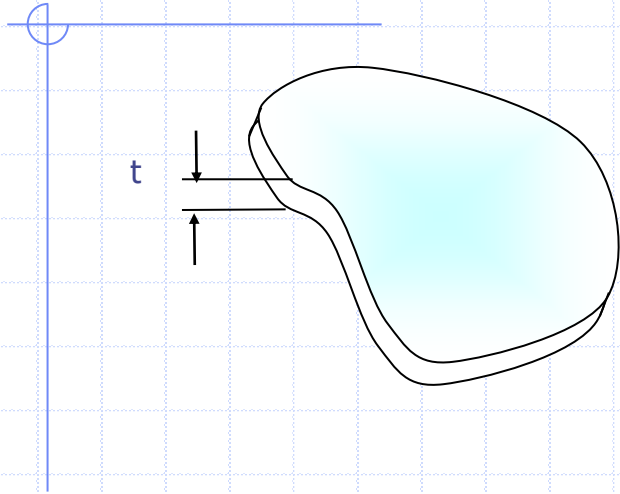

**Tanım:** Ağırlık merkezi  $G$ , parçacıklar sisteminde ağırlığın bileşkesinin olduğu noktadır.

Şekildeki parçacıklar sisteminde  $n$  tane parçacığın her birisinin  **$O$  noktasına göre momentlerinin toplamı**,  $G$  ağırlık merkezindeki  $W$  toplam ağırlığının  $O$  noktasına göre momentine eşit olmalıdır. Bu mantıkla ağırlık merkezinin koordinatları aşağıdaki gibi bulunabilir.

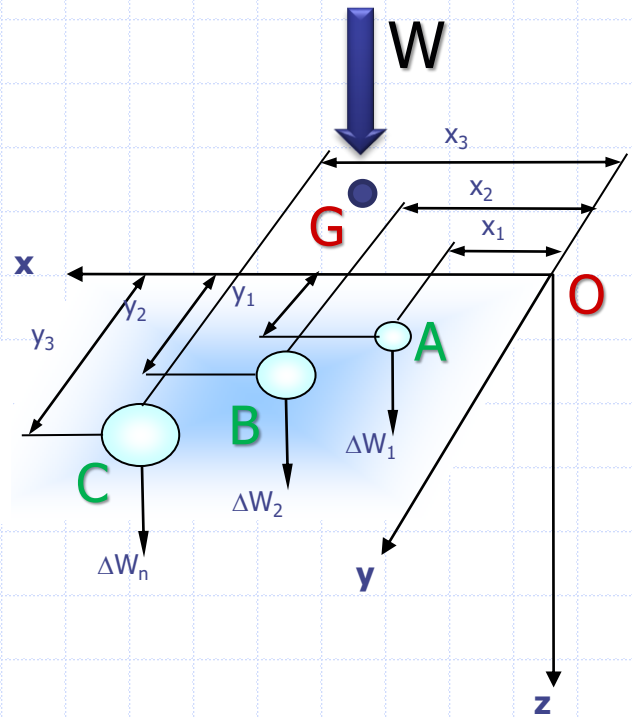

**Toplam Ağırlık:**  $W = W_1 + W_2 + \dots + W_n$

**O'ya göre Moment:**  $\vec{OG} \times \vec{W} = \vec{OA} \times \vec{W}_1 + \vec{OB} \times \vec{W}_2 + \dots + \vec{ON} \times \vec{W}_n$

$$\bar{x} = \frac{x_1 W_1 + x_2 W_2 + \dots + x_n W_n}{W_1 + W_2 + \dots + W_n}$$

$$\bar{y} = \frac{y_1 W_1 + y_2 W_2 + \dots + y_n W_n}{W_1 + W_2 + \dots + W_n}$$

$$\bar{z} = \frac{z_1 W_1 + z_2 W_2 + \dots + z_n W_n}{W_1 + W_2 + \dots + W_n}$$

$$\bar{x} = \frac{\sum_{i=1}^n x_i W_i}{\sum_{i=1}^n W_i}$$

$$\bar{y} = \frac{\sum_{i=1}^n y_i W_i}{\sum_{i=1}^n W_i}$$

$$\bar{z} = \frac{\sum_{i=1}^n z_i W_i}{\sum_{i=1}^n W_i}$$

# Bir Katı Cismin Ağırlık Merkez

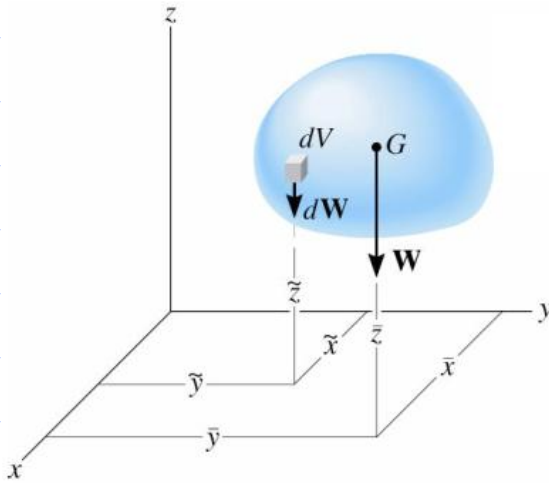

$$\bar{x} = \frac{\sum_{i=1}^n x_i W_i}{\sum_{i=1}^n W_i}$$

$$\bar{x} = \frac{\int \tilde{x} dW}{\int dW}, \quad \bar{y} = \frac{\int \tilde{y} dW}{\int dW}, \quad \bar{z} = \frac{\int \tilde{z} dW}{\int dW}$$

$$\left. \begin{array}{l} \gamma = \text{özgül ağırlık,} \\ dV = \text{diferansiyel hacim,} \end{array} \right\} \text{diferansiyel ağırlık: } dW = \gamma \cdot dV$$

$$\bar{x} = \frac{\int \tilde{x} dW}{\int dW} = \frac{\int \tilde{x} \gamma dV}{\int \gamma dV} = \frac{\cancel{\gamma} \int \tilde{x} dV}{\cancel{\gamma} \int dV} \xrightarrow{1} \bar{x} = \frac{\int \tilde{x} dV}{\int dV} \longrightarrow \text{Hacimsel Merkez}$$

$$2 \rightarrow \bar{y} = \frac{\int \tilde{y} dV}{\int dV} \quad 3 \rightarrow \bar{z} = \frac{\int \tilde{z} dV}{\int dV}$$

Denklemleri homojen bir cismin ağırlık merkezinin koordinatlarını; ayrıca cisim homojen olsun veya olmasın hacimsel merkezini (**geometrik merkezini**) bulmamızı sağlar.

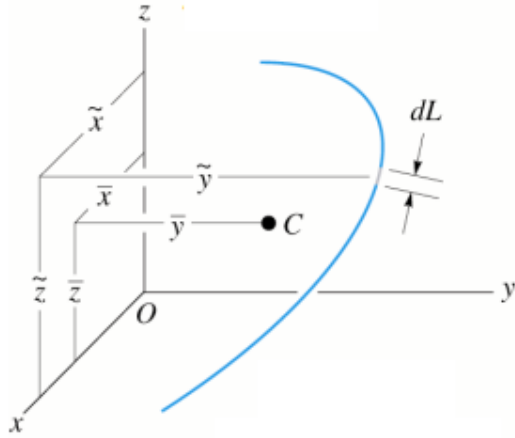

$$\bar{x} = \frac{\int \tilde{x} dL}{\int dL}$$

$$\bar{y} = \frac{\int \tilde{y} dL}{\int dL}$$

$$\bar{z} = \frac{\int \tilde{z} dL}{\int dL}$$

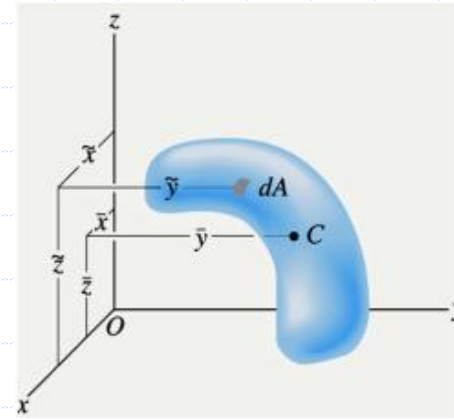

$$\bar{x} = \frac{\int \tilde{x} dA}{\int dA}$$

$$\bar{y} = \frac{\int \tilde{y} dA}{\int dA}$$

$$\bar{z} = \frac{\int \tilde{z} dA}{\int dA}$$

Benzer şekilde; bir alanın veya bir çizginin geometrik merkezleri de sırasıyla alansal merkez veya çizgisel merkez olarak isimlendirilebilir.

Oluşan denklemlerinde **dV** yerine **dA** ve **dL** kullanılarak bulunabilirler.

# Örnek

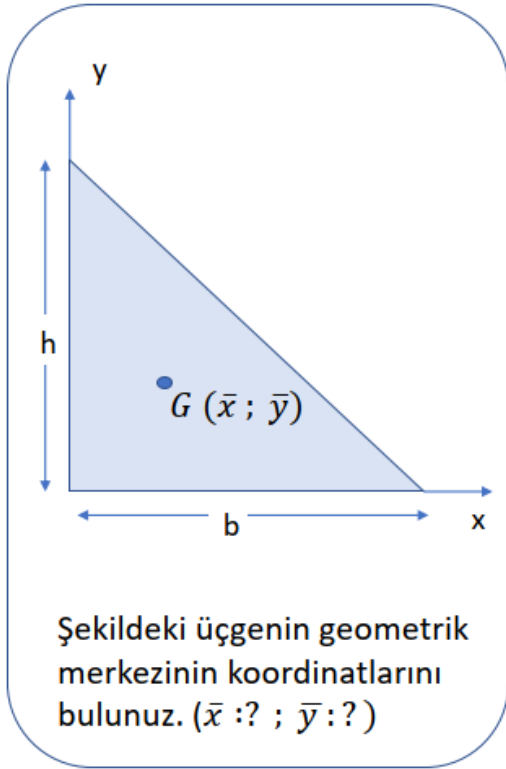

## Çözüm

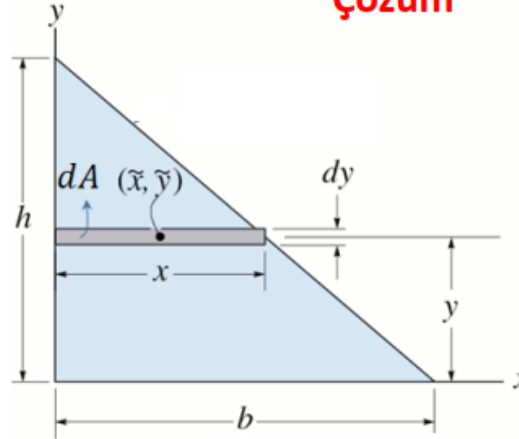

$$\frac{x}{b} = \frac{h-y}{h}$$

$$x = \frac{b \cdot (h-y)}{h}$$

Bir kenarı diferansiyel uzunlukta olan  $dA$  diferansiyel şerit alanı alınır.

$$\tilde{y} = y$$

$$dA = x dy \rightarrow dA = \frac{b}{h}(h-y) dy$$

$$\bar{y} = \frac{\int_A \tilde{y} dA}{\int_A dA} = \frac{\int_0^h y \left( \frac{b}{h}(h-y) \right) dy}{\int_0^h \left( \frac{b}{h}(h-y) \right) dy} = \frac{\frac{1}{6} b h^2}{\frac{1}{2} b h} = \frac{h}{3}$$

$$\bar{x} = \frac{\int_A \tilde{x} dA}{\int_A dA} = \frac{\int_0^h \frac{1}{2} \left( \frac{b}{h}(h-y) \right) \left( \frac{b}{h}(h-y) \right) dy}{\int_0^h \left( \frac{b}{h}(h-y) \right) dy}$$

$$= \frac{\frac{1}{6} b^2 h}{\frac{1}{2} b h} \rightarrow \bar{x} = \frac{b}{3}$$

## Örnek

Dikdörtgenin ağırlık merkezini integral yardımıyla bulunması,

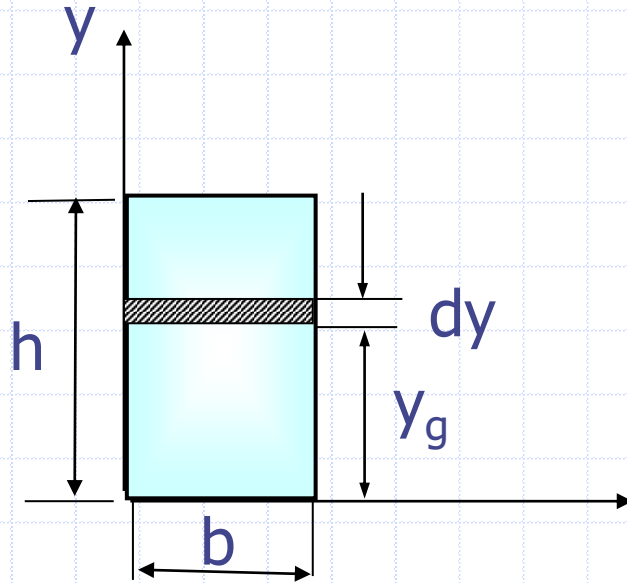

$$\bar{y} = \frac{\int \tilde{y} dA}{\int dA}$$

$$\tilde{y}_g = y \quad dA = b \cdot dy$$

$$\bar{y} = \frac{\int_0^h y \cdot b \cdot dy}{\int_0^h b \cdot dy} = \frac{b \cdot \int_0^h y \cdot dy}{b \cdot \int_0^h dy}$$

$$\bar{y} = \frac{\frac{y^2}{2} \Big|_0^h}{y \Big|_0^h} = \frac{\left(\frac{h^2}{2} - 0\right)}{(h - 0)} = \frac{h}{2}$$

## Örnek

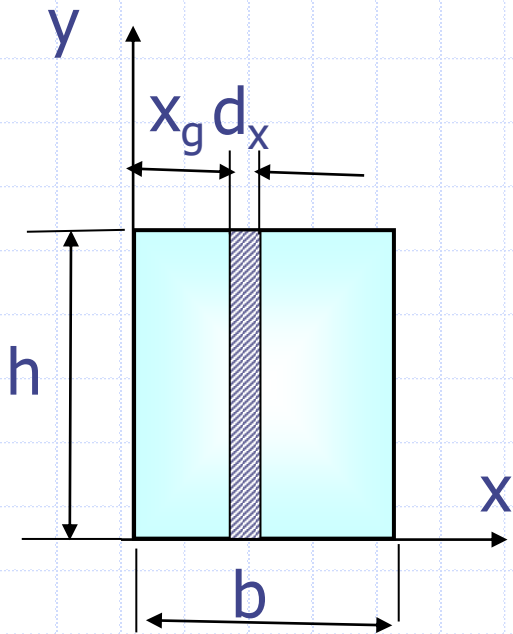

$$\bar{x} = \frac{\int \tilde{x} dA}{\int dA}$$

$$\tilde{x}_g = x \quad dA = h \cdot dx$$

$$\bar{x} = \frac{\int_0^b x \cdot h \cdot dx}{\int_0^b h \cdot dx} = \frac{h \cdot \int_0^b x \cdot dx}{h \cdot \int_0^b dx}$$

$$\bar{y} = \frac{\frac{x^2}{2} I_0^b}{x I_0^b} = \frac{\left(\frac{b^2}{2} - 0\right)}{(b - 0)} = \frac{b}{2}$$

## Örnek

Çeyrek daire için  $\beta$  açısı 0 ile 90 arasındadır

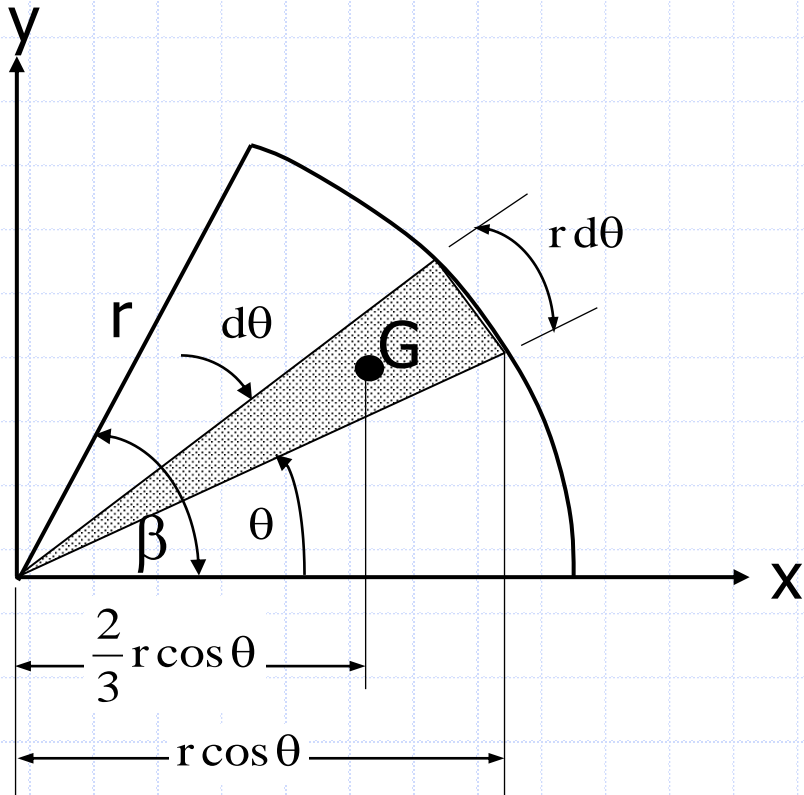

$$dA = \frac{1}{2}(r d\theta)(r) = \frac{1}{2}r^2 d\theta$$

$$A = \int dA = \int_0^{\beta} \frac{1}{2}r^2 d\theta$$
$$= \frac{1}{2}r^2 [\theta]_0^{\beta} = \frac{1}{2}r^2 [\theta]_0^{\frac{\pi}{2}} = \frac{\pi r^2}{4}$$



## Çözüm

$$\bar{x} A = \int x_g dA = \int_0^{\frac{\pi}{2}} \left( \frac{2}{3} r \cos \theta \right) \left( \frac{1}{2} r^2 d\theta \right) = \int_0^{\frac{\pi}{2}} \frac{1}{3} r^3 \cos \theta d\theta$$

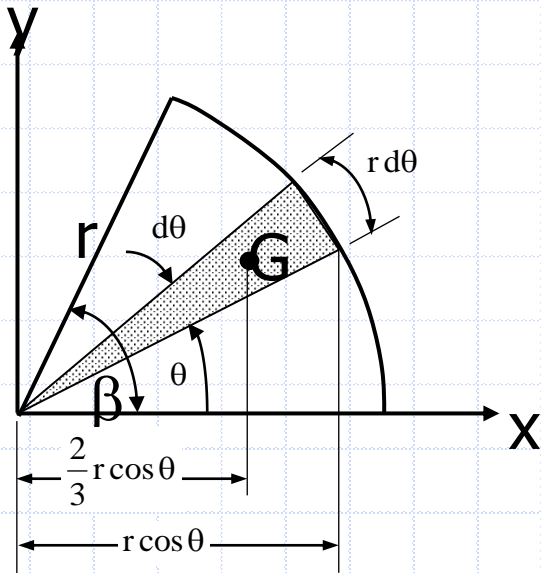
$$= \frac{r^3}{3} \left[ \sin \theta \right]_0^{\frac{\pi}{2}} = \frac{r^3}{3} \left[ \sin \frac{\pi}{2} - 0 \right] = \frac{r^3}{3}$$

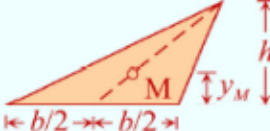
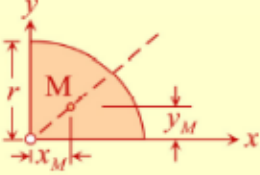
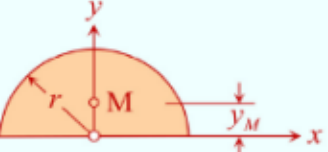

$$\bar{x} = \left( \frac{r^3}{3} \right) \left( \frac{4}{\pi r^2} \right) = \frac{4r}{3\pi}$$

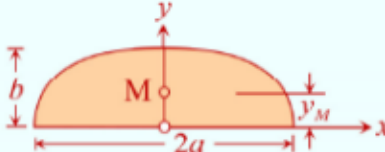
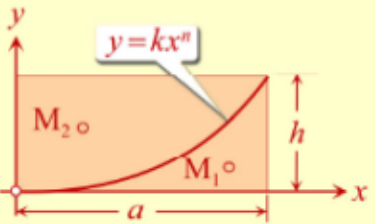
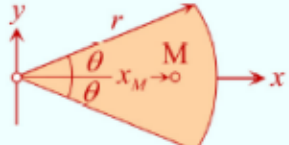
GEOMETRİ		$x_M$	$y_M$	Alan	
üçgen			$\frac{1}{3}h$	$\frac{1}{2}bh$	
1/4 daire		$\frac{4r}{3\pi}$	$\frac{4r}{3\pi}$	$\frac{1}{4}\pi r^2$	
1/2 daire		0	$\frac{4r}{3\pi}$	$\frac{1}{2}\pi r^2$	
1/4 elips		$\frac{4a}{3\pi}$	$\frac{4b}{3\pi}$	$\frac{1}{4}\pi ab$	
1/2 elips		0	$\frac{4b}{3\pi}$	$\frac{1}{2}\pi ab$	
Parabol parçası		①	$\frac{(n+1)}{(n+2)}a$	$\frac{(n+1)}{(4n+2)}h$	$\frac{ah}{(n+1)}$
		②	$\frac{(n+1)}{(2n+4)}a$	$\frac{(n+1)}{(2n+1)}h$	$\frac{n}{(n+1)}(ah)$
Daire dilimi		$\frac{2r \sin \theta}{3\theta}$	0	$\theta r^2$	

## *Homojen ve Simetri varsa !*

- Homojen bir cismin kütle merkezi, varsa, simetri düzlemi üzerindedir.
- Eğer birbirini kesen iki tane simetri düzlemi varsa simetri düzlemlerinin kesişme doğrusu üzerindedir.



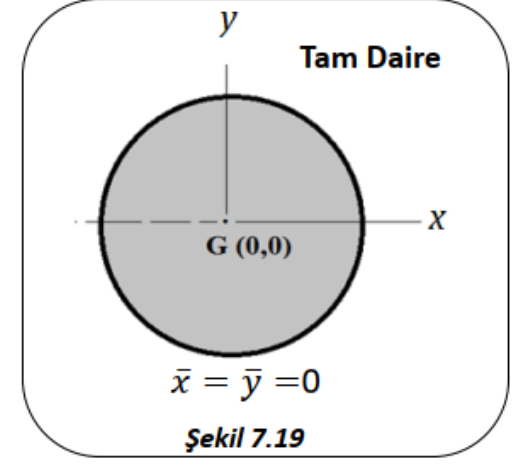
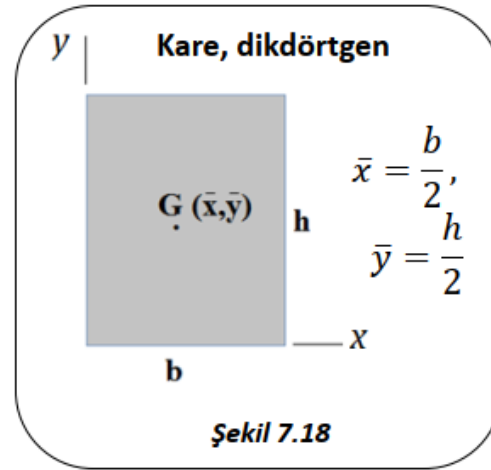
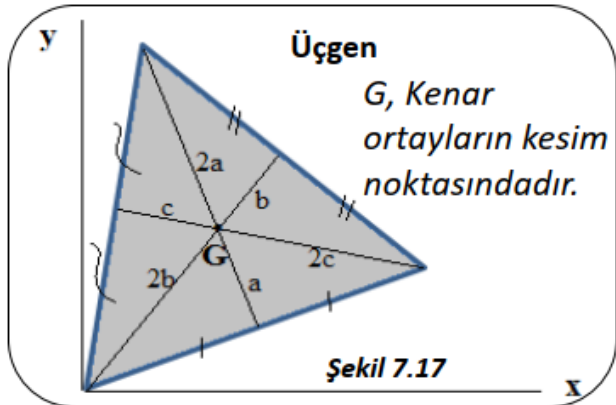
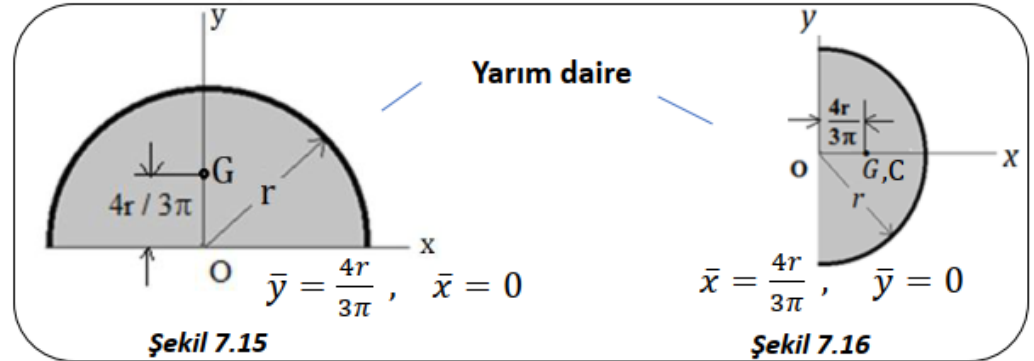
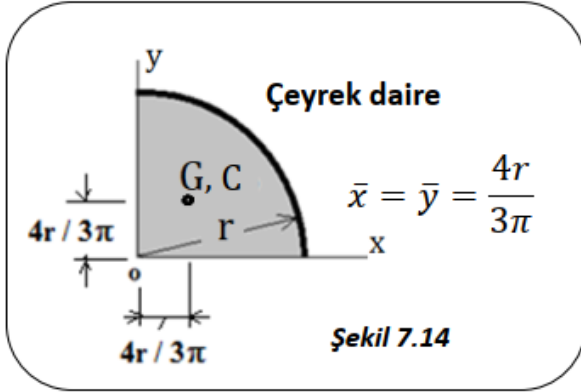

# BİRLEŞİK ALANLARIN AĞIRLIK MERKEZİ

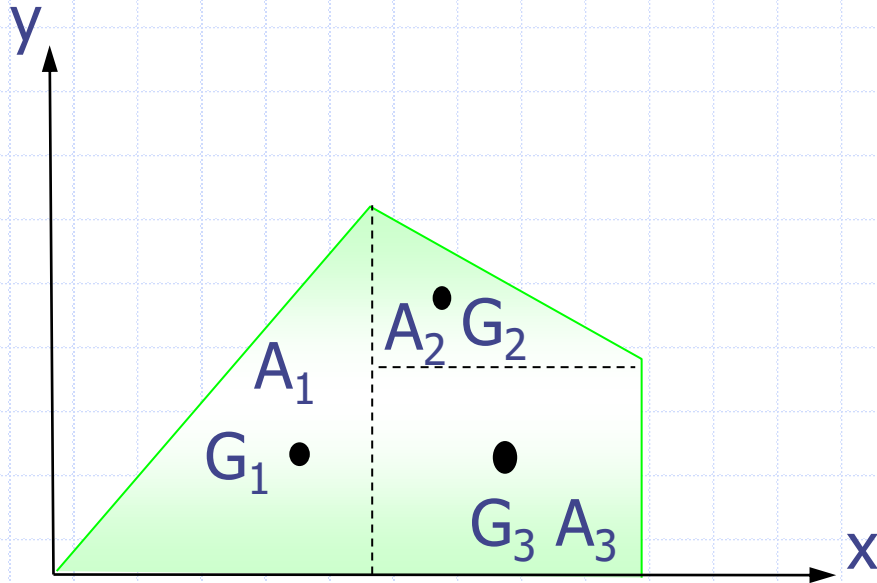

$$G_1 = (x_1, y_1)$$

$$G_2 = (x_2, y_2)$$

$$G_3 = (x_3, y_3)$$

$$A = A_1 + A_2 + A_3$$
$$xA = x_1 A_1 + x_2 A_2 + x_3 A_3$$

$$x = \frac{x_1 A_1 + x_2 A_2 + x_3 A_3}{A} = \frac{\sum_{i=1}^n x_i A_i}{\sum_{i=1}^n A}$$

$$y = \frac{y_1 A_1 + y_2 A_2 + y_3 A_3}{A} = \frac{\sum_{i=1}^n y_i A_i}{\sum_{i=1}^n A}$$

## Örnek

Ağırlık merkezinin koordinatlarını bulunuz.

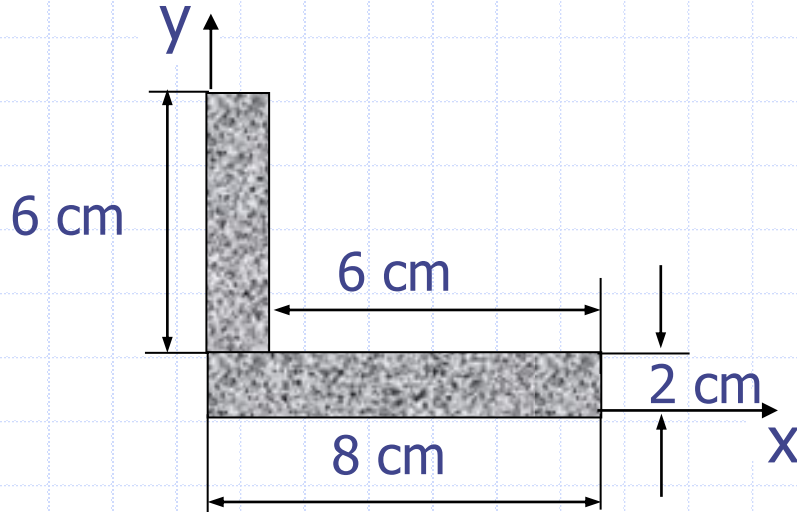

$$x = \frac{x_1 A_1 + x_2 A_2}{A}$$

$$\frac{1 \cdot (12) + 4 \cdot (16)}{28} = \frac{76}{28} = 2,71 \text{ cm}$$

$$y = \frac{y_1 A_1 + y_2 A_2}{A}$$

$$\frac{5 \cdot (12) + 1 \cdot (16)}{28} = \frac{76}{28} = 2,71 \text{ cm}$$

# ***DÖNEL CİSİMLER ( PAPPUS GULDİN TEOREMLERİ )***

## **Guldin kuraları:**

**1.Kural:** Bir düzlem eğrinin bir eksen etrafında dönmesi sonucu oluşan cismin manto(yüzey) alanı aşağıdaki basit yolla hesaplanır.  $A_{\text{manto}}=2 \pi L d_1$

L: eğrinin uzunluğu

$d_1$  :Eğrinin ağırlık merkezinin eksene mesafesi

**2.Kural:** Bir düzlem alanın bir eksen etrafında dönmesi sonucu oluşan cismin hacmi aşağıdaki basit yolla hesaplanır.

$$V=2 \pi A d_2$$

A: düzlem cismin alanı

$d_2$  : alanın ağırlık merkezinin eksene mesafesi

## Örnek

Yarım çember yayından küre yüzey alanının elde edilmesi

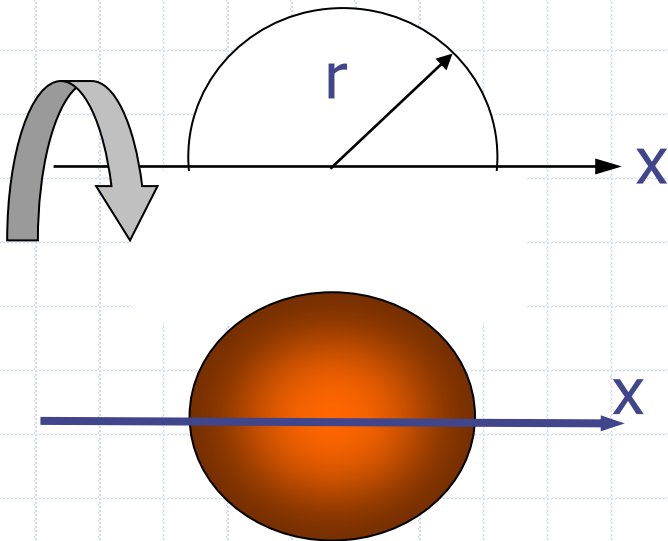

$$A_{manto} = 2\pi L d_1$$

$$L = \pi r \quad d_1 = \frac{4r}{3\pi}$$

$$A_{manto} = 2\pi \cdot \pi r \cdot \frac{4r}{3\pi}$$

$$A_{manto} = \frac{8}{3} \pi r^2$$

## Örnek

Eğik bir doğrunun x eksenini etrafında döndürülmesi ile koni yüzey alanının hesabı

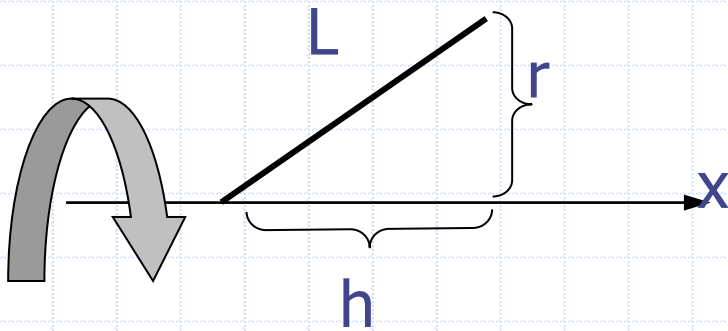

$$A_{manto} = 2\pi L d_1$$

$$A_{manto} = 2\pi \cdot L \cdot \frac{r}{2}$$

$$A_{manto} = \pi \cdot r \cdot L$$

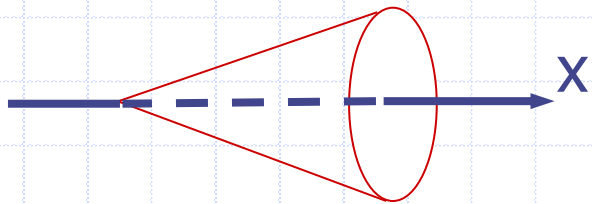

## Örnek

Çemberden tor yüzey alanının hesabı

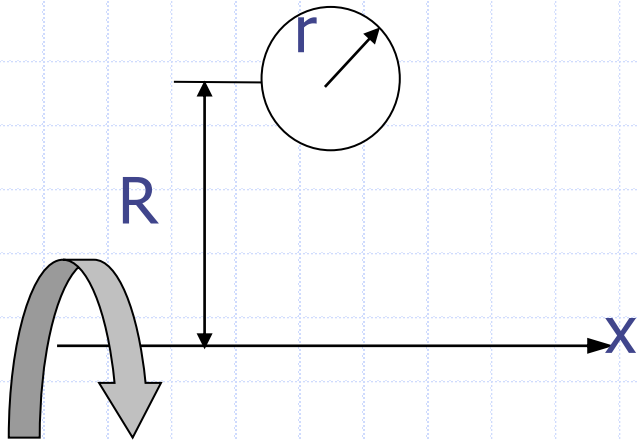

$$A_{manto} = 2\pi L d_1$$

$$A_{manto} = 2\pi \cdot 2\pi \cdot R$$

$$A_{manto} = 4 \cdot \pi^2 \cdot R$$

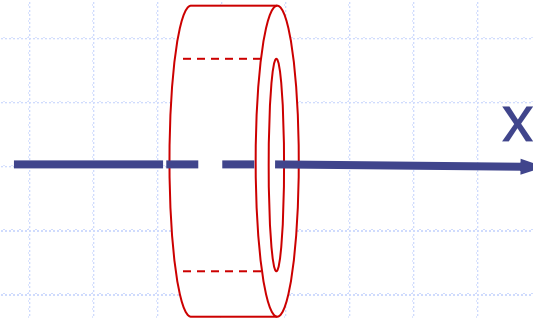

## Örnek

x eksenine paralel bir doğrudan silindir yüzey alanının elde edilmesi

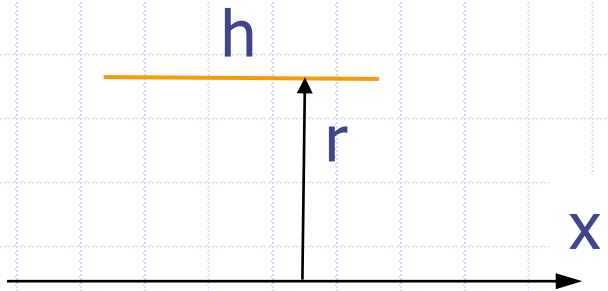

$$A_{manto} = 2\pi L d_1$$

$$A_{manto} = 2\pi \cdot h \cdot r$$

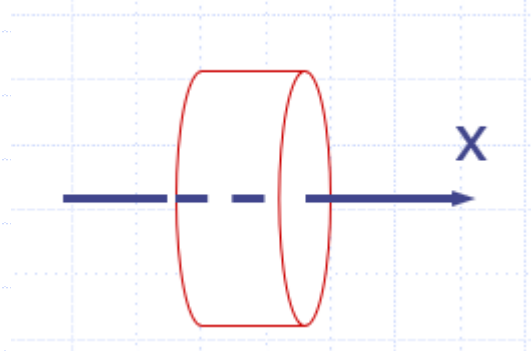

## PAPPUS GULDİN 2. Kural Örnekleri

Yarım daireden kürenin hacminin hesabı

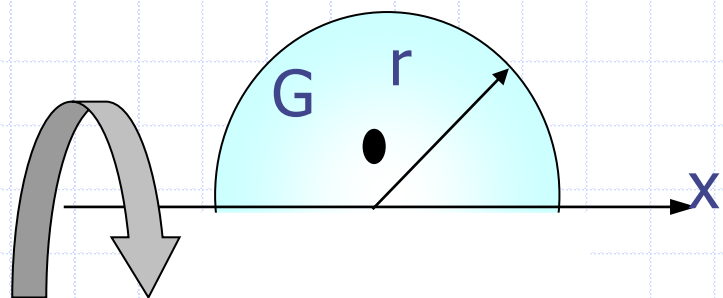

$$V = 2\pi \cdot A \cdot d_2$$

$$V = 2\pi \cdot A \cdot d_2$$

$$V = 2\pi \cdot \frac{\pi r^2}{2} \cdot \frac{4r}{3\pi}$$

$$V = \frac{4\pi r^3}{3}$$

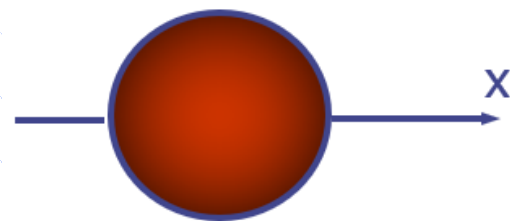

## Örnek

Dikdörtgenden dolu silindirin hacminin hesabı

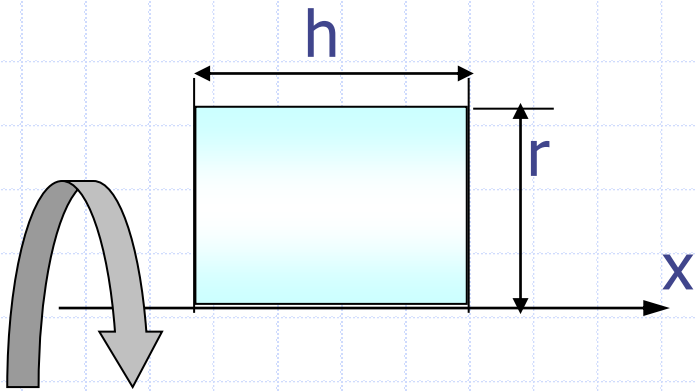

$$V = 2\pi \cdot A \cdot d_2$$

$$V = 2\pi \cdot hr \cdot \frac{r}{2}$$

$$V = \pi \cdot r^3 \cdot h$$

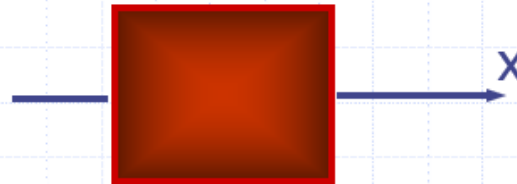

## Örnek

Üçgenden koni hacminin hesabı

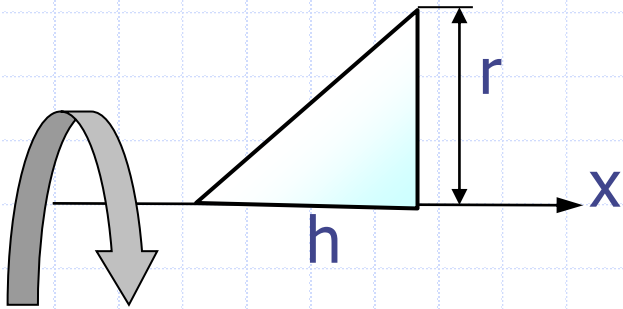

$$V = 2\pi \cdot A \cdot d_2$$

$$V = 2\pi \cdot \frac{rh}{2} \cdot \frac{r}{3}$$

$$V = \frac{\pi r^2 h}{3}$$

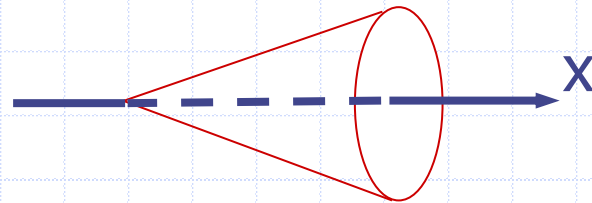

## Örnek - Ödev

Dolu daireden R yarıçaplı torun hacmi nedir?

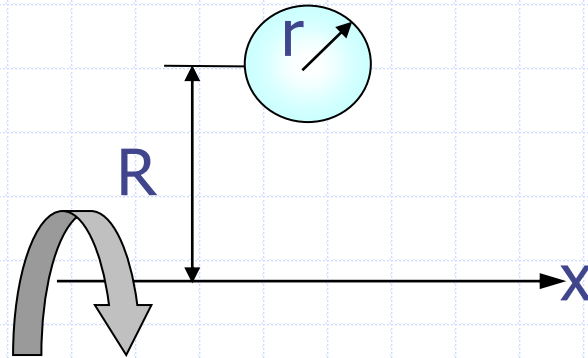

# ÇÖZÜMLÜ PROBLEMLER

## Örnek 1

Taralı alanın ağırlık merkezinin koordinatlarını hesaplayınız.

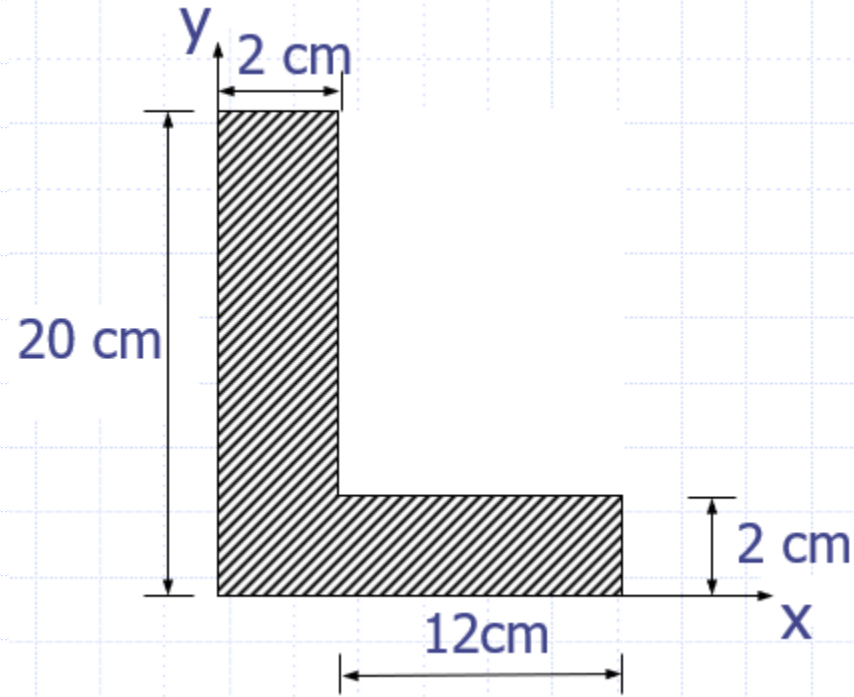

**Çözüm:**

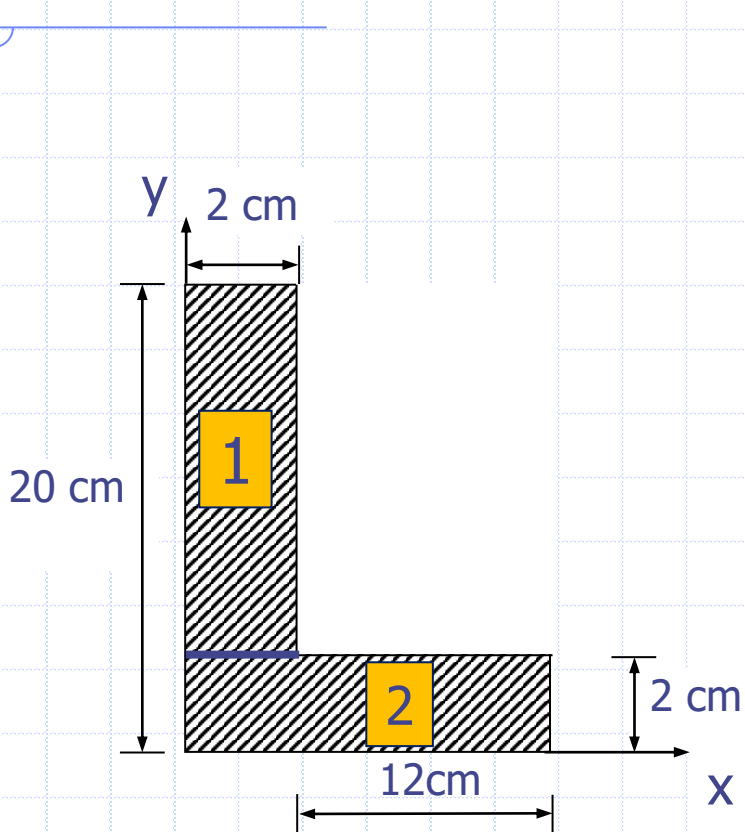

$$\bar{X} = \frac{A_1 \cdot x_1 + A_2 \cdot x_2}{A_1 + A_2} = \frac{40 \cdot 1 + 24 \cdot 8}{64} = 3,625 \text{ cm}$$

$$\bar{Y} = \frac{A_1 \cdot y_1 + A_2 \cdot y_2}{A_1 + A_2} = \frac{40 \cdot 10 + 24 \cdot 1}{64} = 6,625 \text{ cm}$$

## Örnek 2

Taralı alanın ağırlık merkezinin koordinatlarını hesaplayınız.

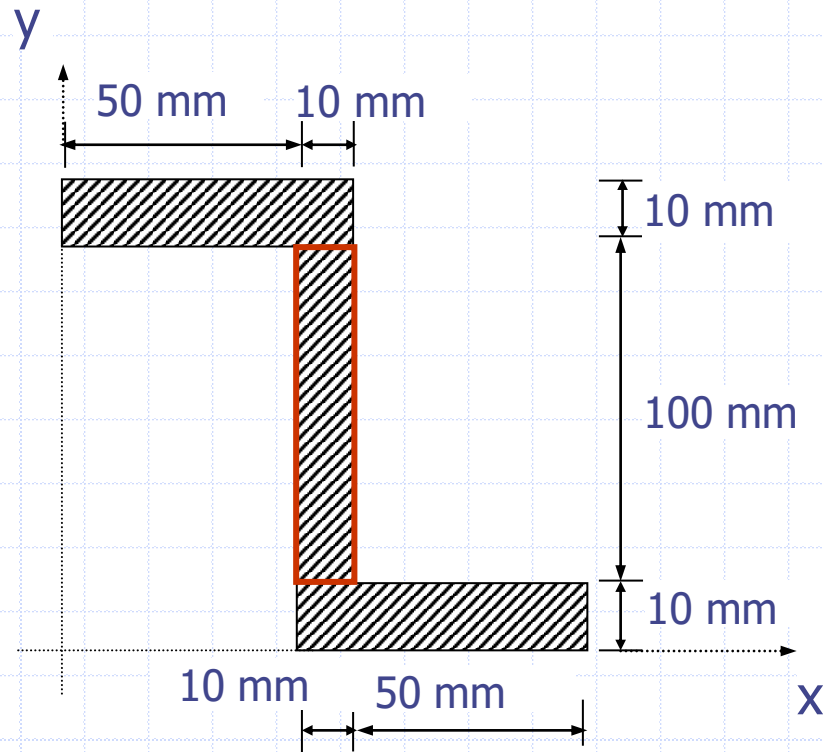

## Çözüm:

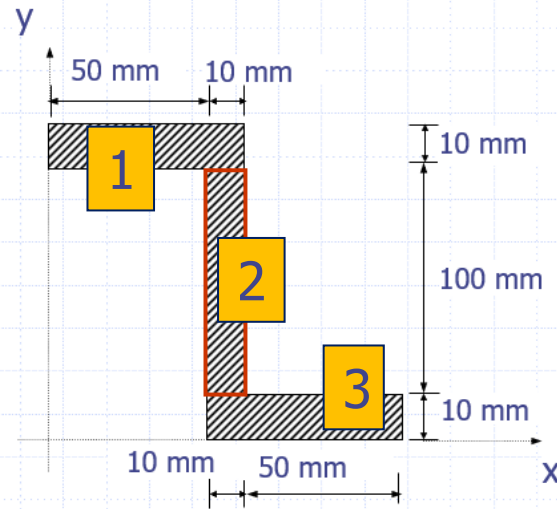

$$\bar{X} = \frac{x_1 \cdot A_1 + x_2 \cdot A_2 + x_3 \cdot A_3}{A_1 + A_2 + A_3} = \frac{30 \cdot (60 \cdot 10) + 55 \cdot (10 \cdot 100) + 80 \cdot (10 \cdot 60)}{600 + 1000 + 600} = 55 \text{ mm}$$

$$\bar{Y} = \frac{y_1 \cdot A_1 + y_2 \cdot A_2 + y_3 \cdot A_3}{A_1 + A_2 + A_3} = \frac{115 \cdot (60 \cdot 10) + 60 \cdot (10 \cdot 100) + 5 \cdot (10 \cdot 60)}{600 + 1000 + 600} = 60 \text{ mm}$$

### Örnek 3

Taralı alanın ağırlık merkezinin koordinatlarını hesaplayınız.

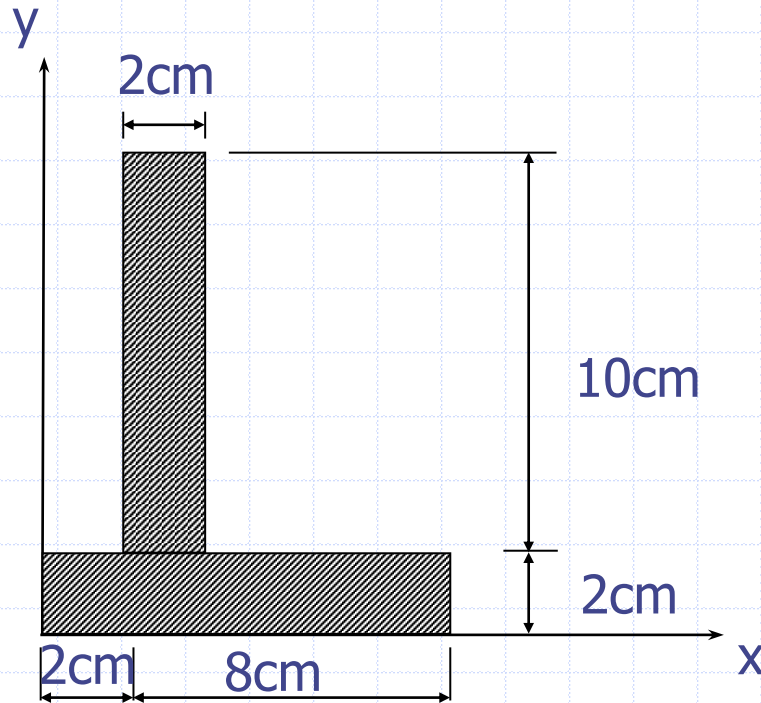

## Çözüm:

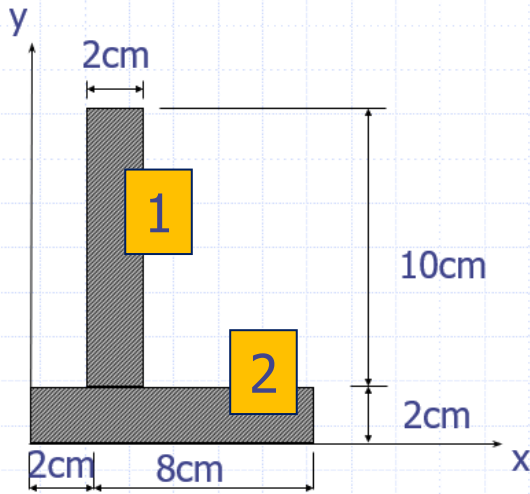

	<b><i>x</i></b>	<b><i>y</i></b>	<b><i>A</i></b>	<b><u><i>Ax</i></u></b>	<b><i>Ay</i></b>
<b>1</b>	3	7	20	60	140
<b>2</b>	5	1	20	100	120
<b>Toplam</b>			40	160	160

$$\bar{x} = \frac{x_1 A_1 + x_2 A_2}{A_1 + A_2} = \frac{160}{40} \Rightarrow \bar{x} = 4 \text{ cm}$$

$$\bar{y} = \frac{y_1 A_1 + y_2 A_2}{A_1 + A_2} = \frac{160}{40} \Rightarrow \bar{y} = 4 \text{ cm}$$

## Örnek 4

Taralı alanın ağırlık merkezinin koordinatlarını hesaplayınız.

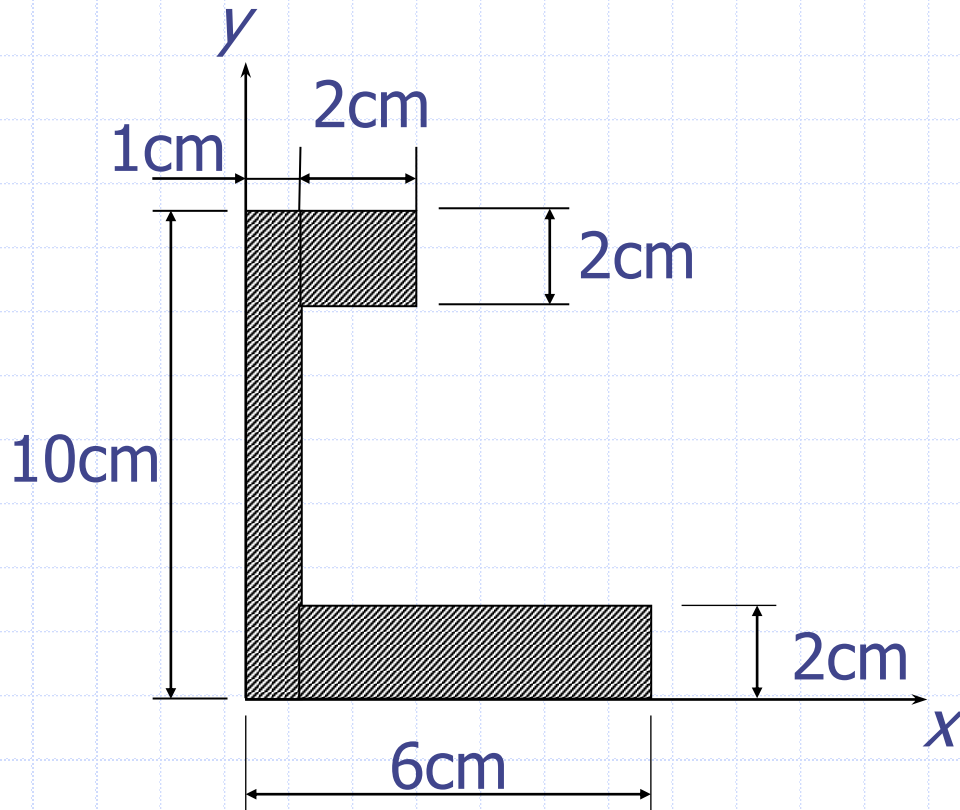

## Çözüm:

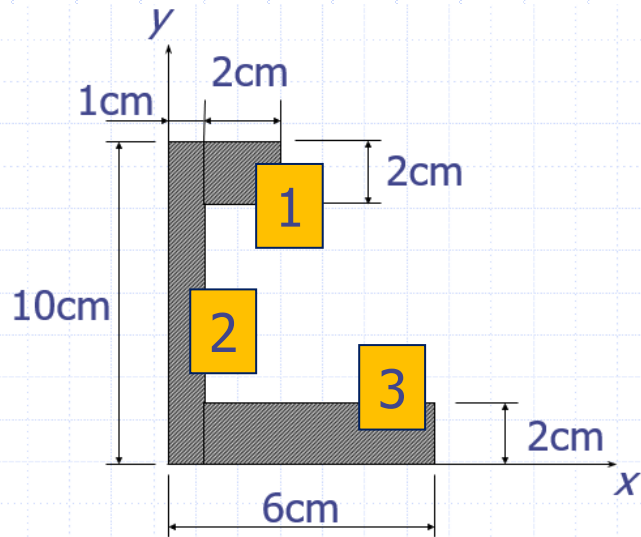

	<b>x</b>	<b>y</b>	<b><u>Ax</u></b>	<b>Ay</b>	<b>A</b>
<b>1</b>	2	9	4	8	36
<b>2</b>	0,5	5	10	5	50
<b>3</b>	3,5	1	10	35	10
<b>Toplam</b>			24	48	96

$$\bar{x} = \frac{\Sigma xA}{\Sigma A} = \frac{48}{24} = 2 \text{ cm}$$

$$\bar{y} = \frac{\Sigma yA}{\Sigma A} = \frac{96}{24} = 4 \text{ cm}$$

## Örnek 5

Verilen profil kesitte ağırlık merkezini, yerini hesaplayınız. (ölçüler cm'dir)

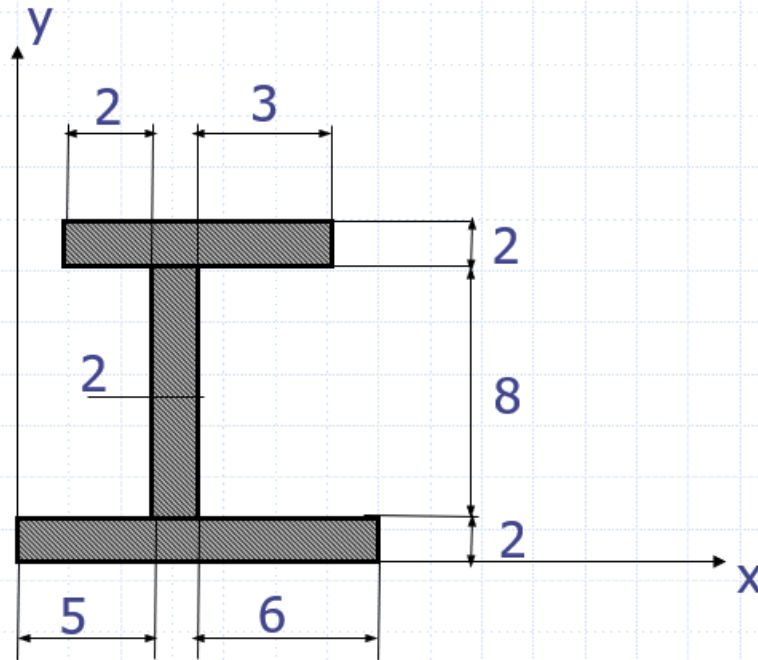

**Çözüm:**

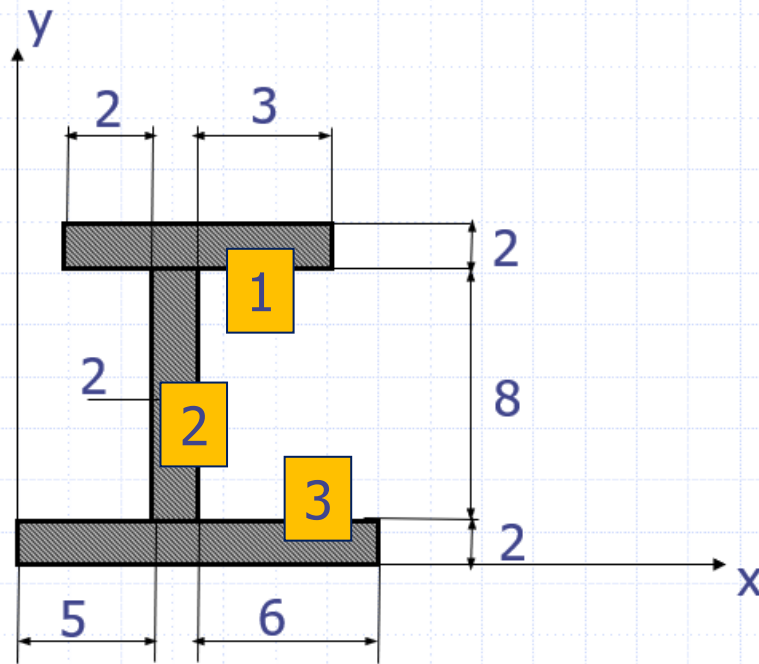

	<b>A</b>	<b>x</b>	<b>y</b>	<b>Ax</b>	<b>Ay</b>
<b>1</b>	14	6,5	11	91	154
<b>2</b>	16	6	6	96	96
<b>3</b>	26	6,5	1	169	26
<b>T</b>	56			356	276

$$\bar{x} = \frac{356}{56} = 6,35 \text{ cm}$$

$$\bar{y} = \frac{276}{56} = 4,92 \text{ cm}$$

## Örnek 6

Taralı alanın ağırlık merkezinin koordinatlarını hesaplayınız.

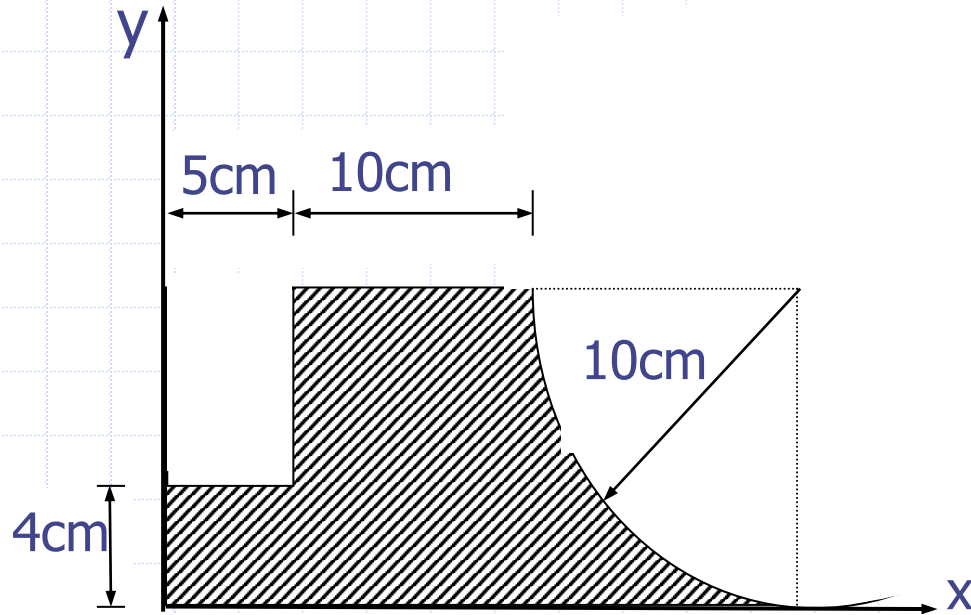

**Çözüm:**

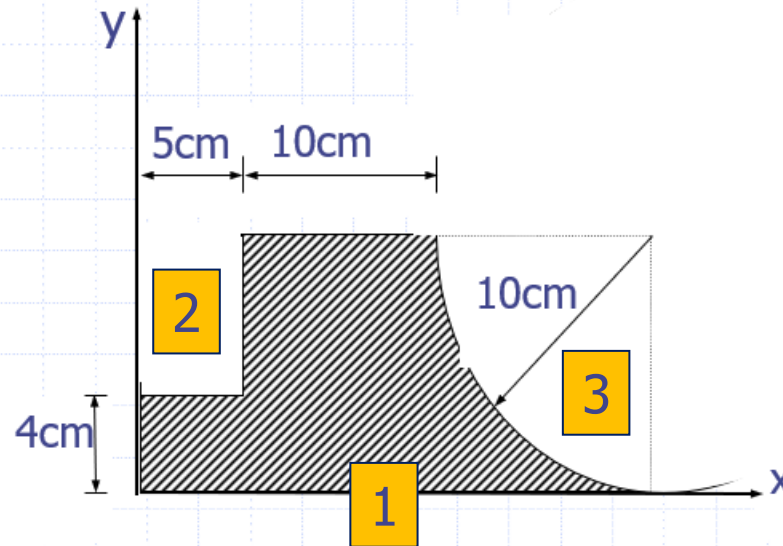

	<b>X</b>	<b>Y</b>	<b>AX.</b>	<b>AY.</b>	<b>A</b>
<b>1</b>	12,5	5	250	3125	1250
<b>2</b>	2,5	7	-30	-75	-210
<b>3</b>	20,76	5,76	-78,53	-1630,28	-452,33
<b>Toplam</b>			141,47	1419,72	587,67

$$\bar{X} = \frac{\sum x.A}{\sum A} = \frac{1419,72}{141,47} = 10,03 \text{ cm} \quad \bar{Y} = \frac{\sum y.A}{\sum A} = \frac{587,67}{141,47} = 4,15 \text{ cm}$$

## Örnek 7

Verilen şeklin ağırlık merkezinin koordinatlarını bulunuz.

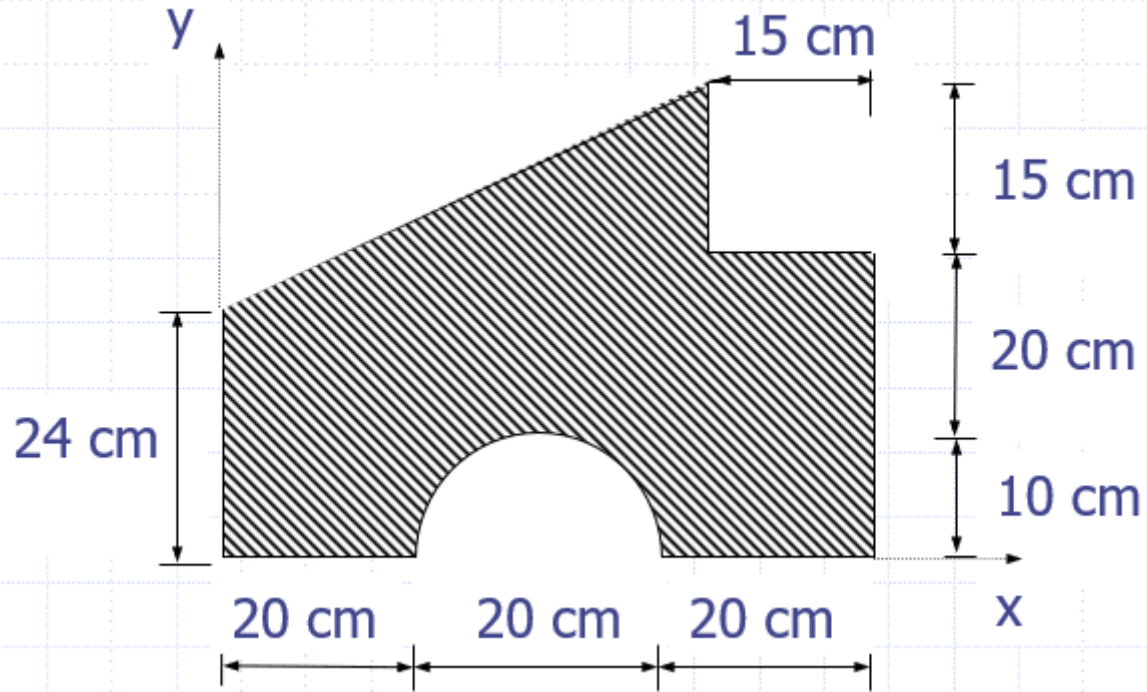

## Çözüm:

	<b>X</b>	<b>Y</b>	<b>AX.</b>	<b>AY.</b>	<b>A</b>
<b>1</b>	30	22,5	2700	81000	60750
<b>2</b>	15	38	-472,5	-7087,5	-17955
<b>3</b>	52,5	37,5	-225	-11812,5	-8437,5
<b>4</b>	30	4,24	-157,08	-4712,4	-666
<b>Toplam</b>			1845,42	57387,6	33691,5

$$\bar{X} = \frac{\sum x.A}{\sum A} = \frac{57387,6}{1845,42} = 31,09cm$$

$$\bar{Y} = \frac{\sum y.A}{\sum A} = \frac{33691,5}{1845,42} = 18,25cm$$