



Techniques for synthesis of nanomaterials (I)

Lecture 110

MTX9100
Nanomaterials

OUTLINE

- What are the possible approaches to making nanomaterials?
- Which technologies can be used to produce nanostructures using a top-down approach?
- What is bottom –down approach?

How to get at nano scale?

There are **two general approaches** to the synthesis of nanomaterials and the fabrication of nanostructures

Bottom-up approach

These approaches include the miniaturization of materials components (up to atomic level) with further self-assembly process leading to the formation of nanostructures.

During self-assembly the physical forces operating at nanoscale are used to combine basic units into larger stable structures.

Typical examples are quantum dot formation during epitaxial growth and formation of nanoparticles from colloidal dispersion.

Top-down approach

These approaches use larger (macroscopic) initial structures, which can be externally-controlled in the processing of nanostructures.

Typical examples are etching through the mask, ball milling, and application of severe plastic deformation.

Top-down vs. bottom-up

- **Top-down methods**

begin with a pattern generated on a larger scale, then reduced to nanoscale.

- By nature, aren't cheap and quick to manufacture
- Slow and not suitable for large scale production.

- **Bottom-up methods**

start with atoms or molecules and build up to nanostructures

- Fabrication is much less expensive

Top-Down: lithography

At the moment, the most used top-down approach is photolithography. It has been used for a while to manufacture computer chips and produce structures smaller than 100 nm.

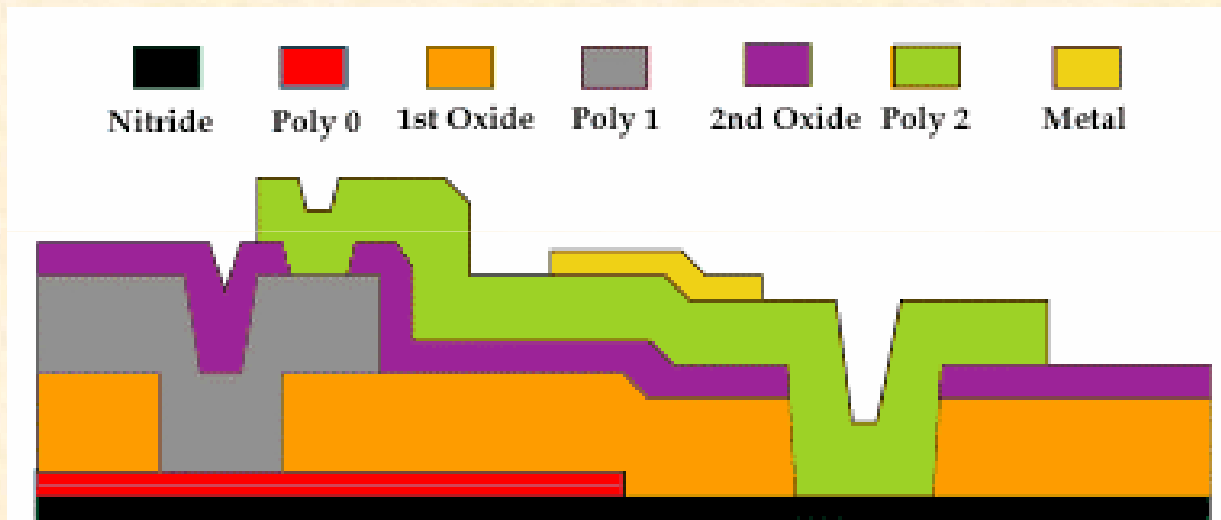

Strip resist and do process again and again. Eventually, a 3-D structure is built up

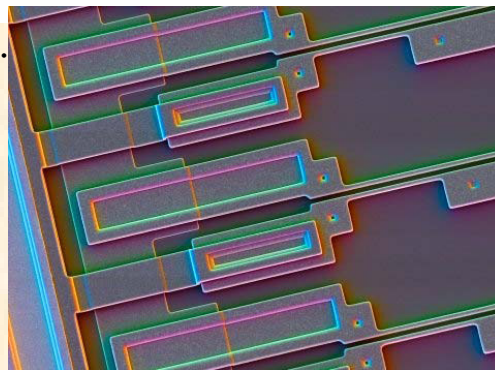

Typically, an oxidized silicon (Si) wafer is coated with a 1 μ m thick photoresist layer. After exposure to ultraviolet (UV) light, the photoresist undergoes a photochemical reaction, which breaks down the polymer by rupturing the polymer chains. Subsequently, when the wafer is rinsed in a developing solution, the exposed areas are removed.

Basic idea behind lithographic processing

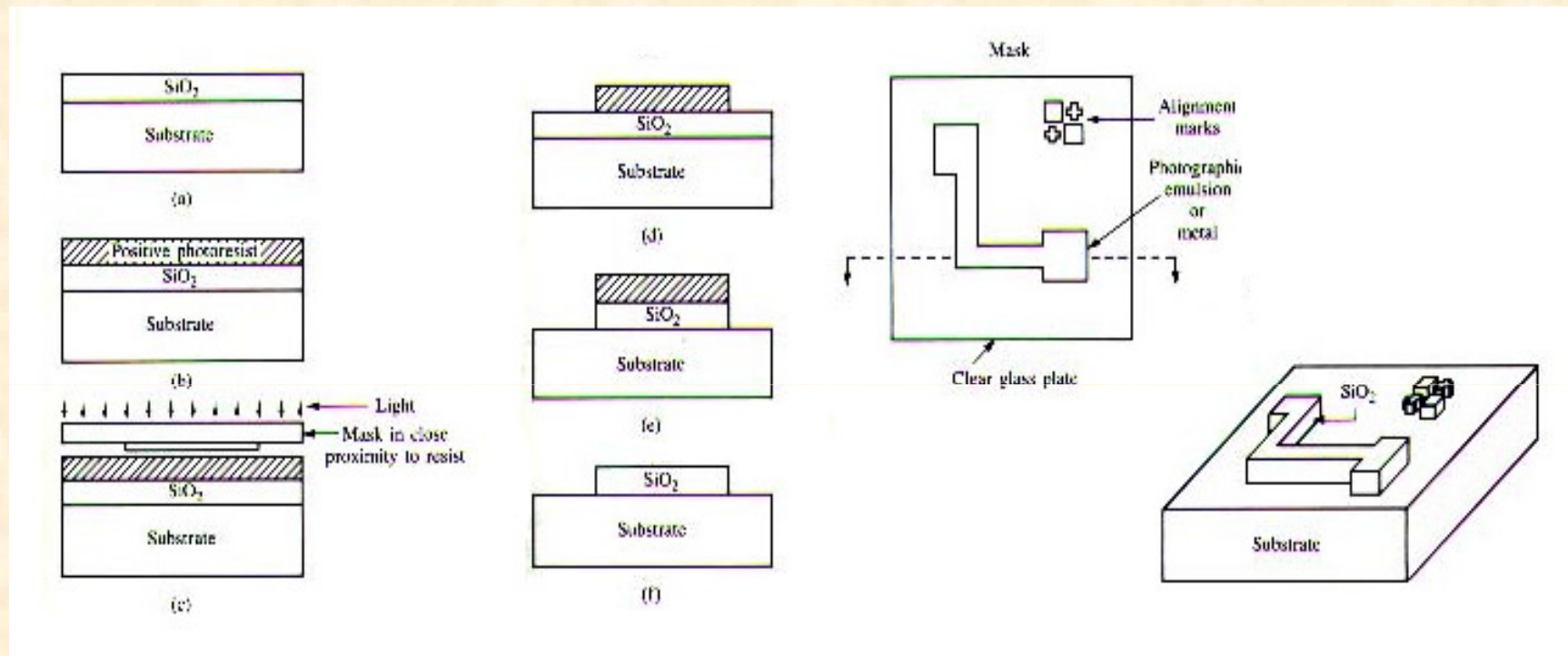

Coat, protect, expose, etch, repeat...

Result:

Multiple patterned layers of different materials.

Top-Down: photolithography

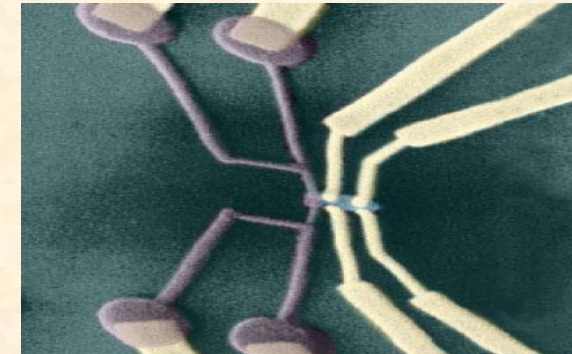
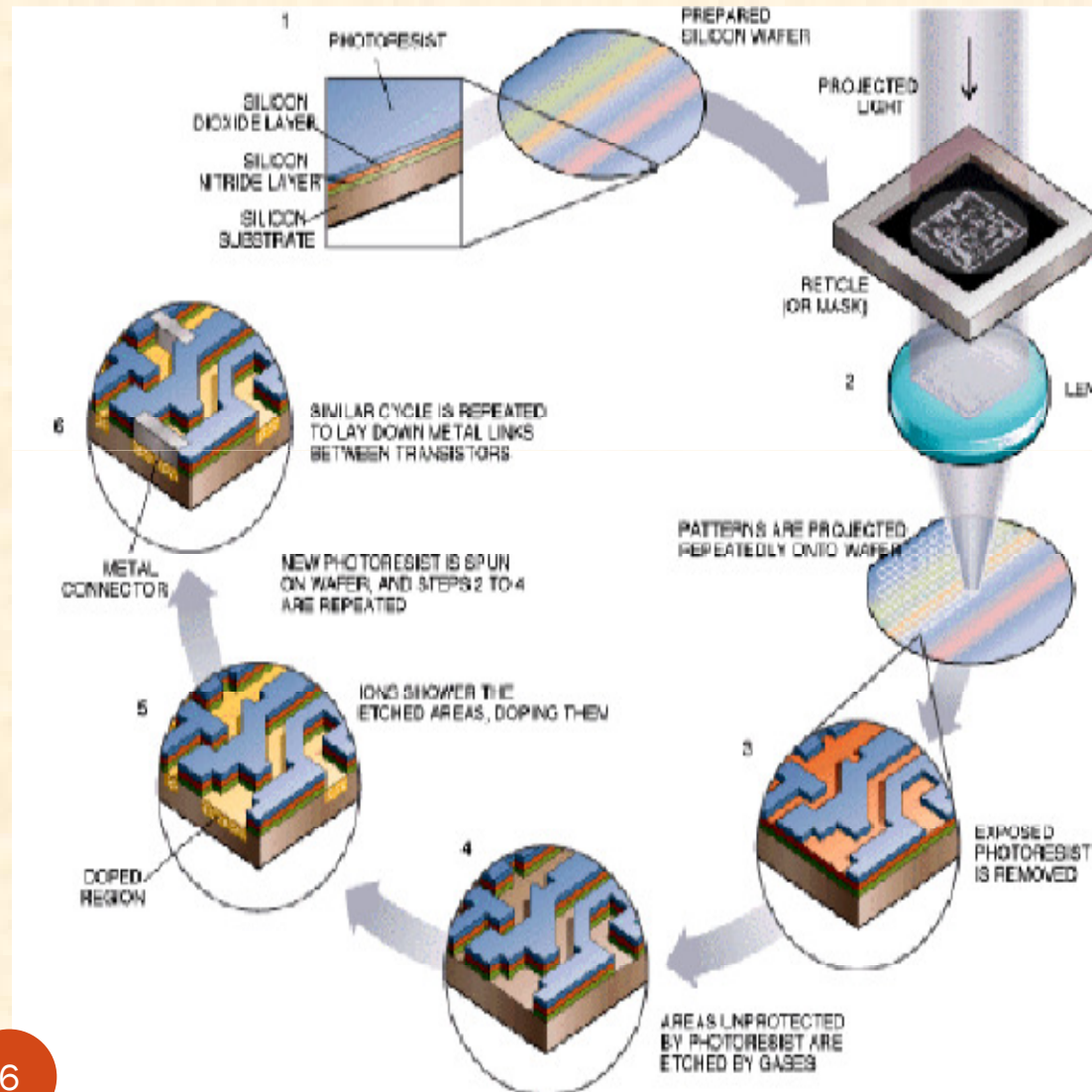

Ferromagnetic/superconducting devices (e-beam lithography)

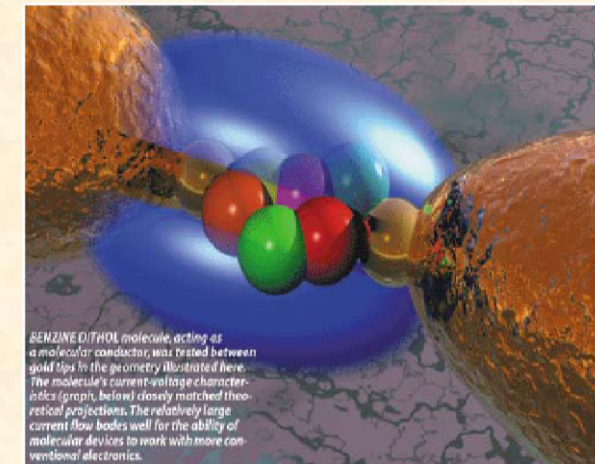

Molecular electronics (e-beam lithography)

Lithographic processing: Masking and exposure

Expose resist to UV light through a mask

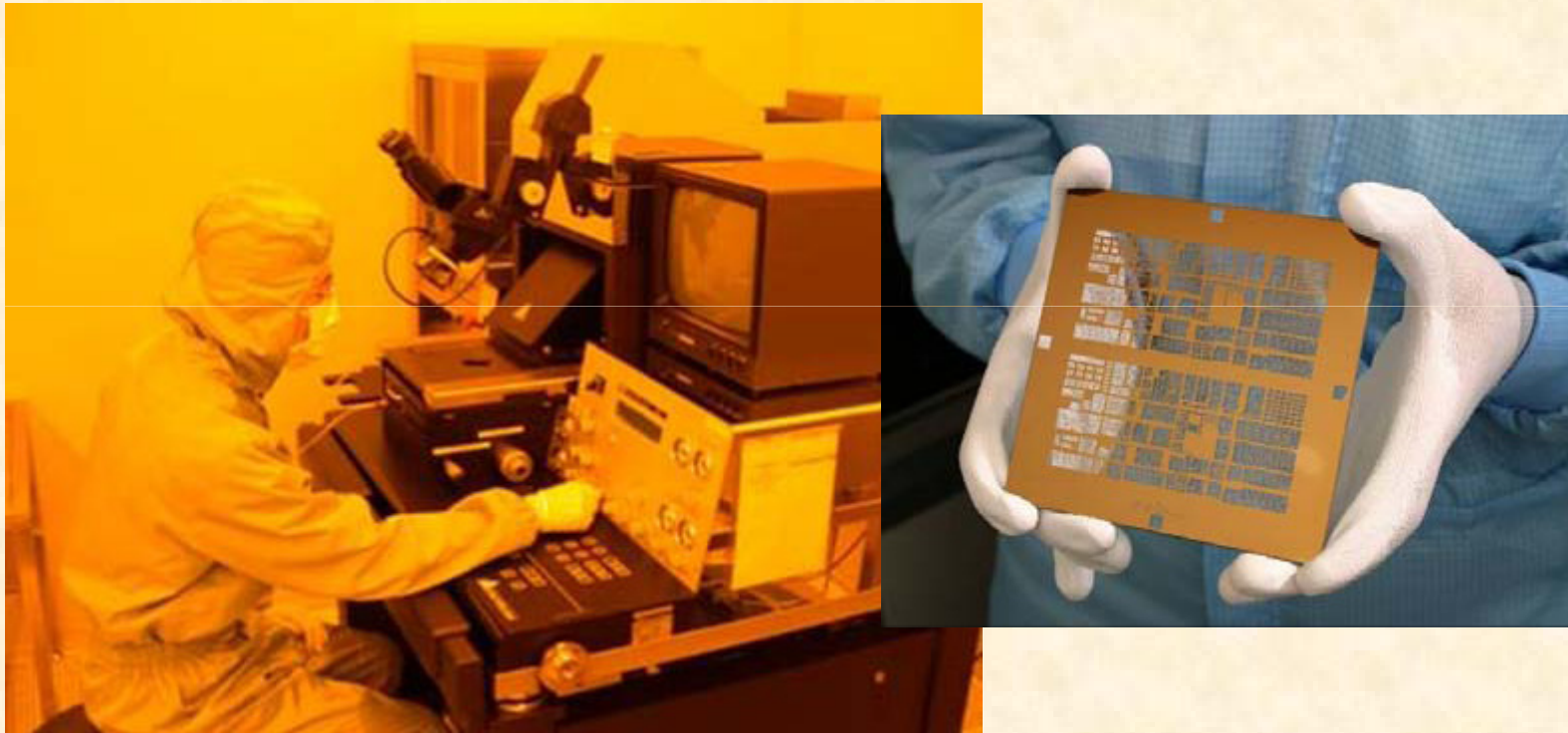

Mask is aligned to wafer before exposure.

Lithographic processing: Developing the pattern

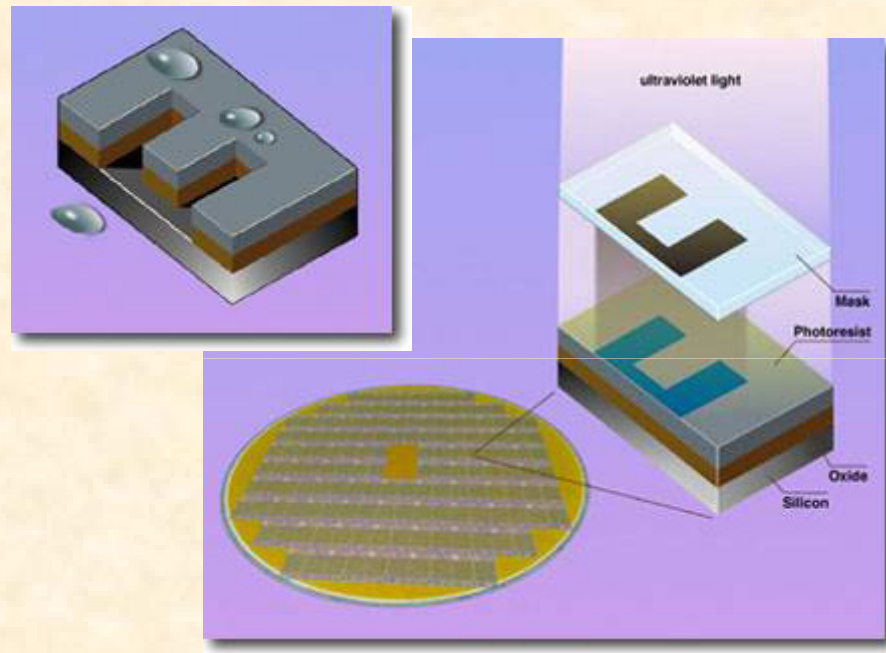

Resist is removed from exposed areas

Remaining resist faithfully reproduces mask pattern

Lithographic processing: Etch the material

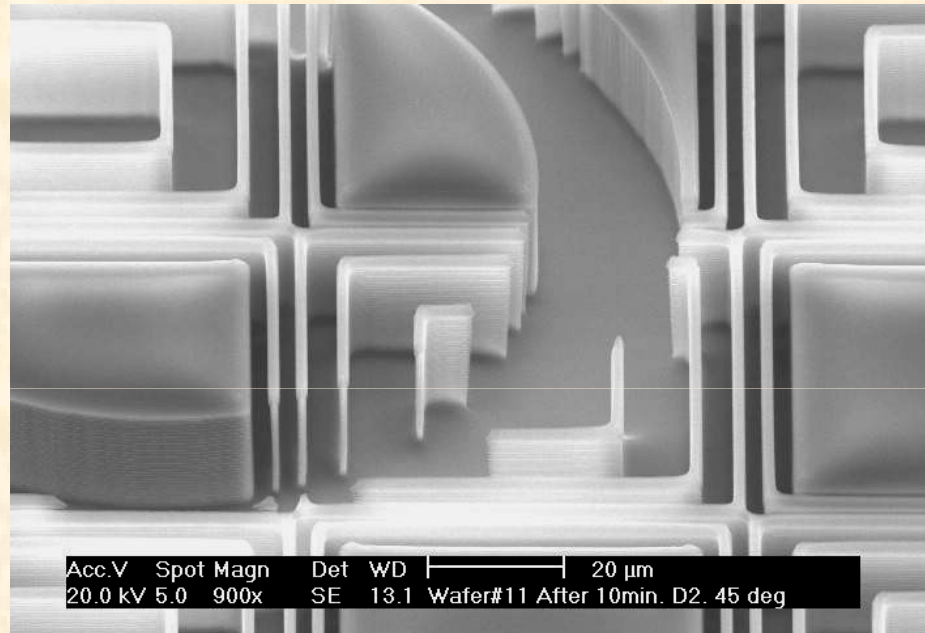

Resist protects selected regions during etch.

Pattern is transferred to substrate material.

Problems in lithography

Though the concept of photolithography is simple, the actual implementation is very **complex and expensive**.

This is because

- (1) nanostructures significantly smaller than 100 nm are difficult to produce due to diffraction effects,
- (2) masks need to be perfectly aligned with the pattern on the wafer,
- (3) the density of defects needs to be carefully controlled, and
- (4) photolithographic tools are very costly, ranging in price from tens to hundreds of millions of dollars.

Electron-beam lithography

Electron-beam lithography and **X-ray lithography** techniques have been developed as alternatives to photolithography.

In the case of **electron beam lithography**, the pattern is written in a polymer film with a beam of electrons.

Since diffraction effects are largely reduced due to the wavelength of electrons, there is no blurring of features, and thus the resolution is greatly improved.

However, the electron beam technique is very **expensive** and very **slow**.

In the case of **X-ray lithography**, diffraction effects are also minimized due to the short wavelength of X-rays, but conventional lenses are not capable of focusing X-rays and the radiation damages most of the materials used for masks and lenses.

The most recent lithography methods

Printing, stamping, and molding use mechanical processes instead of photons or electrons.

These methods are normally called **soft lithography** methods because they involve the use of polymers.

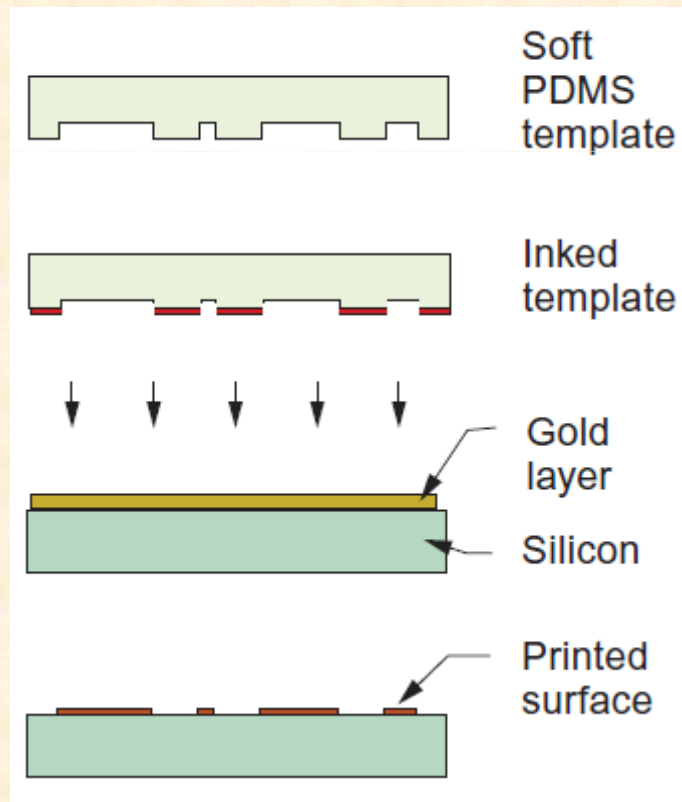

microcontact printing method

A chemical precursor to polydimethylsiloxane (PDMS) is poured over and cured into the rubbery solid PDMS stamp that reproduces the original pattern.

The stamp can then be used in various inexpensive ways to make nanostructures.

The stamp is inked with a solution consisting of organic molecules and then pressed into a thin film of gold on a silicon plate.

The organic molecules form a self-assembled monolayer on the solid surface that reproduces the pattern with a precision of approximately 50 nm.

Advantages of lithography

- Once the master template has been made, no special equipment is required.
- Soft lithographic methods are capable of producing nanostructures in a wide range of materials and can print or mold on curved as well as planar surfaces

Photolithography. A beam of UV light activates the photoresist, transferring the pattern from the mask to the sample.

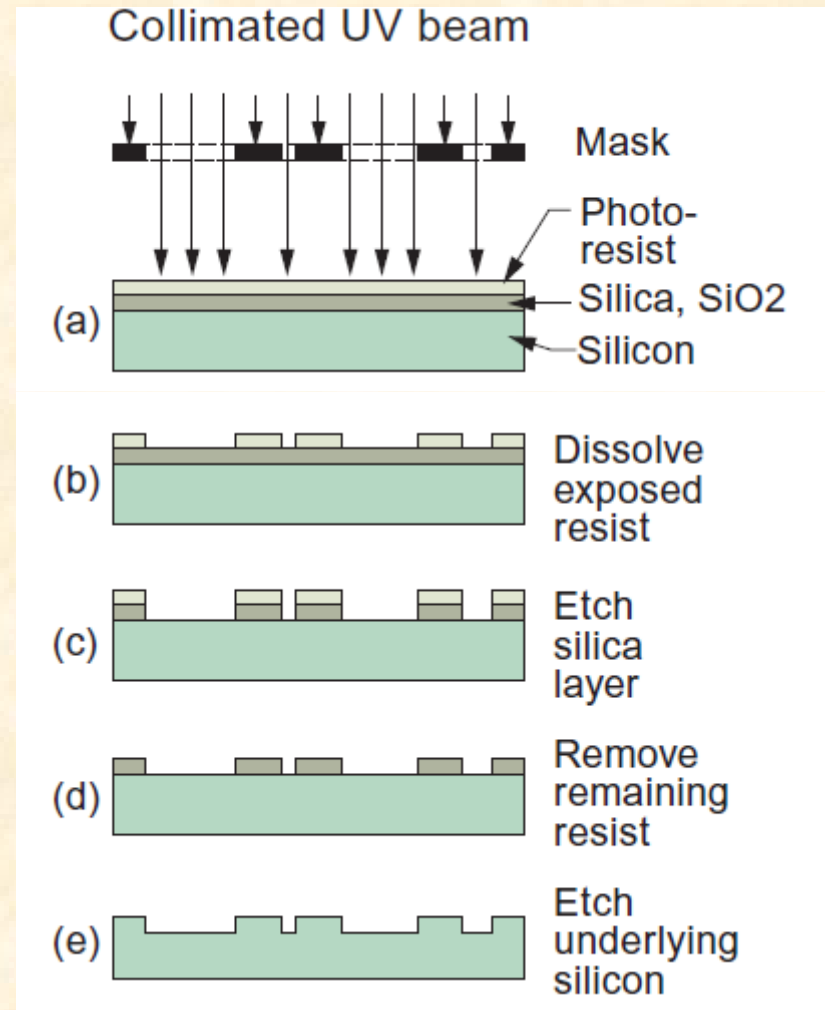

Nanosphere lithography

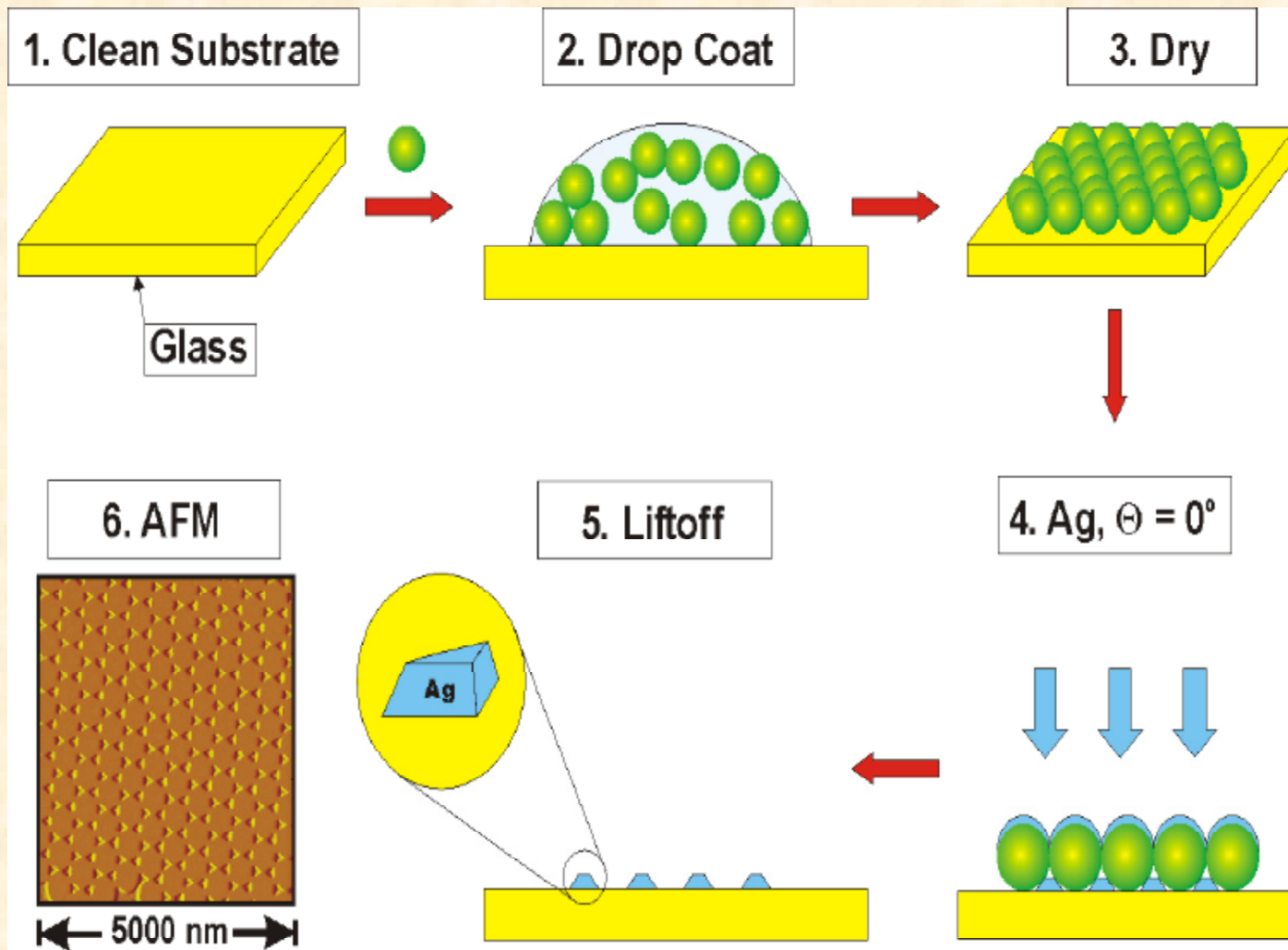

Micromachining methods

Machining Method	Materials That Can Be Machined	Feature Size (and Tolerance)	Positional Tolerance	Material Removal Rate, Microns ³ /sec
Micromachining	Metals, polymers	10 microns (2 microns)	3 microns	10,000
Micro electrodischarge machining (EDM)	Any conducting material	10 microns (3 microns)	3 microns	2,500,000
Electron beam machining (EBM)	Any conducting material	5 microns (submicron)	1 micron	100,000
Femto-second laser machining (LBM)	Any material	1 micron (submicron)	Submicron	13,000
Focused ion-beam machining (FIB)	Any material	0.2 microns (0.02 microns)	0.1 microns	0.5

Focused ion-beam (FIB) machining

FIB machining offers the **greatest resolution**, with the ability to make features as small as 20 nm, but it is very **slow**.

In FIB a beam of gallium ions from a liquid metal ion source is accelerated, filtered, and focused with electromagnetic lenses to give a spot size of 5-8 nm.

The beam is tracked across the surface, contained in a chamber under high vacuum.

The high-energy ions blast atoms from the surface, allowing simple cutting of slots and channels or the creation of more elaborate 3-D shapes. Secondary electrons are emitted when the gallium ions displace the surface atoms. These can be used to image the surface, allowing observation and control of the process as it takes place.

Dual-beam FIBs have an additional electron gun that is used as an alternative way of imaging. The precision is **extraordinary**.

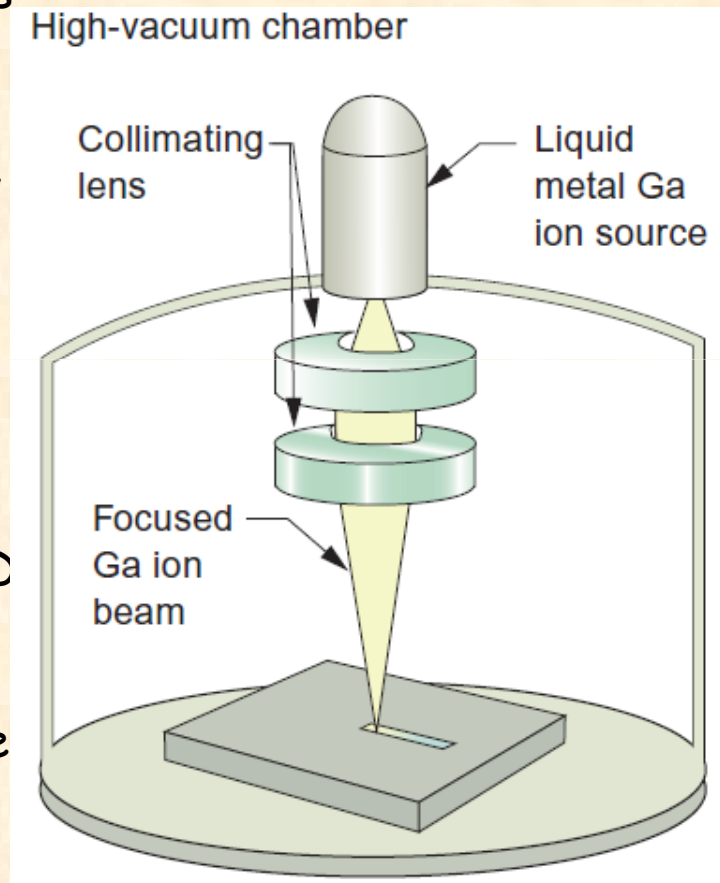

Growth and patterning ("top down" and "bottom up")

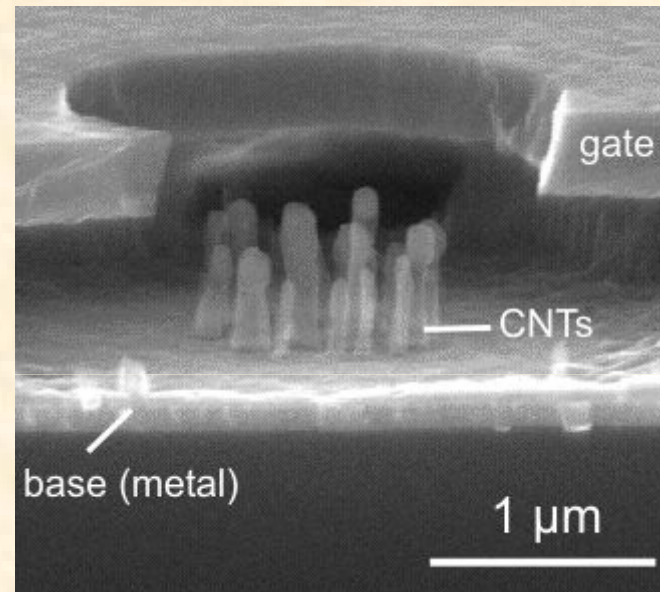
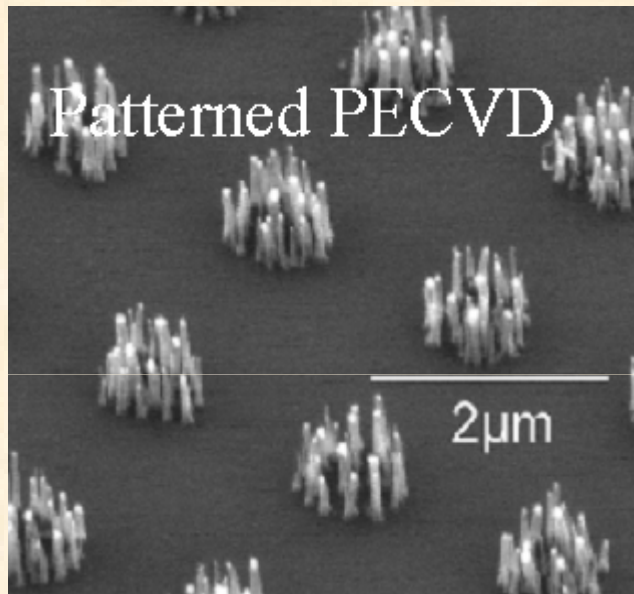

Nano-scale structures and micro-scale structures are readily formed using top down and bottom up approaches.
Best chance for integration.

New Method : Bottom Up + Top Down

17

Self-assembled block copolymers + Optical lithography

Bottom-up methods

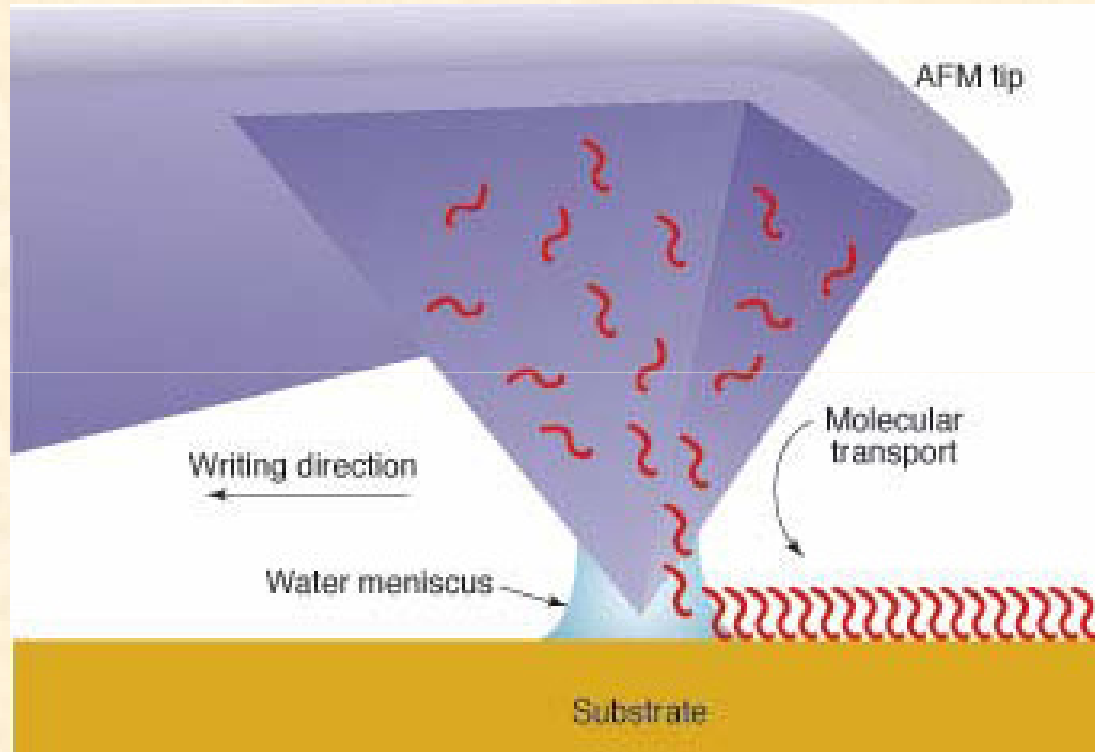

1. High precision actuators move atoms from place to place
2. Micro tips emboss or imprint materials
3. Electron (or ion) beams are directly moved over a surface

1. Chemical reactors create conditions for special growth
2. Biological agents sometimes used to help process
3. Materials are harvested for integration

Bottom-Up: Molecular self-assembly

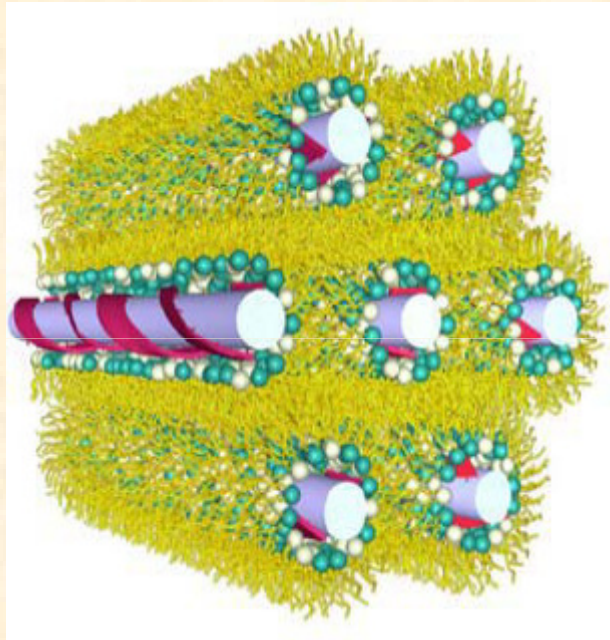

Polythiophene wires

- Nature uses self-assembly in infinitely subtler ways; indeed, the whole of the natural world is self-assembled.
- Spontaneous organization of molecules into stable, structurally well-defined aggregates (nanometer length scale).
- Molecules can be transported to surfaces through liquids to form self-assembled monolayers (SAMs).

Self-assembly examples

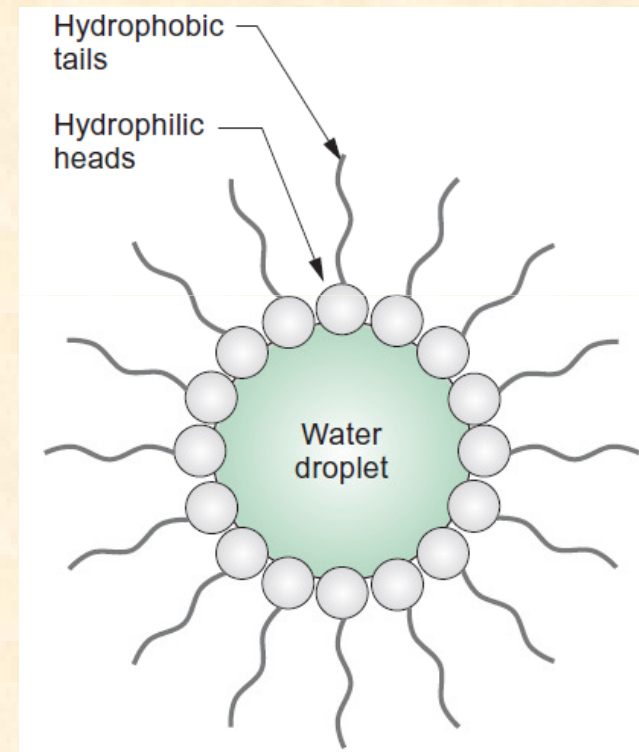
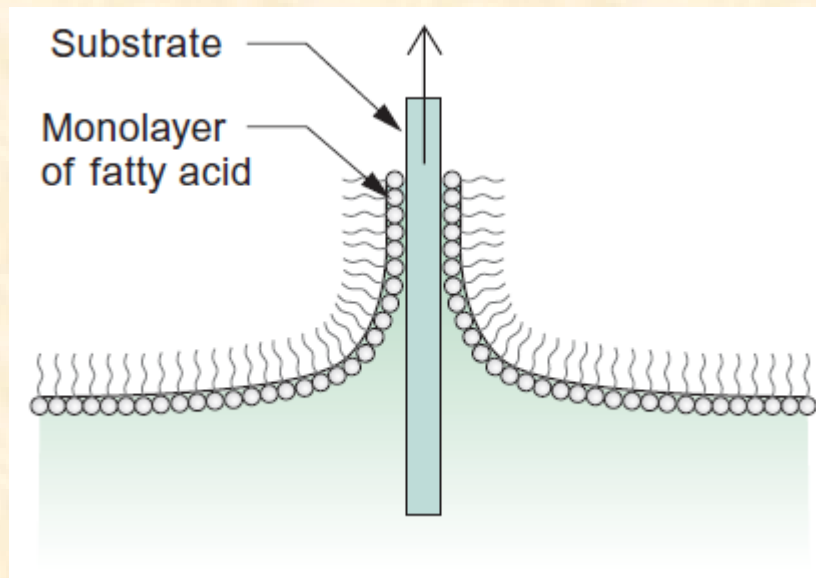
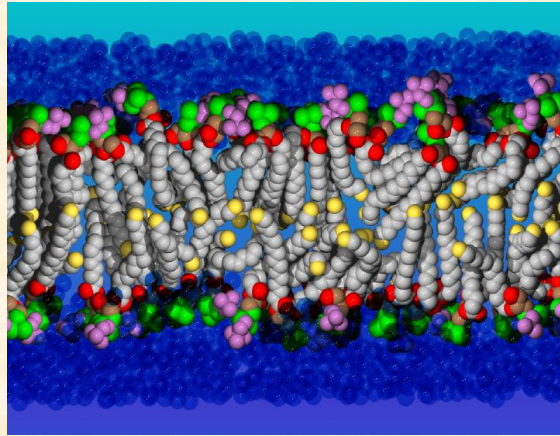

Atomic layer deposition

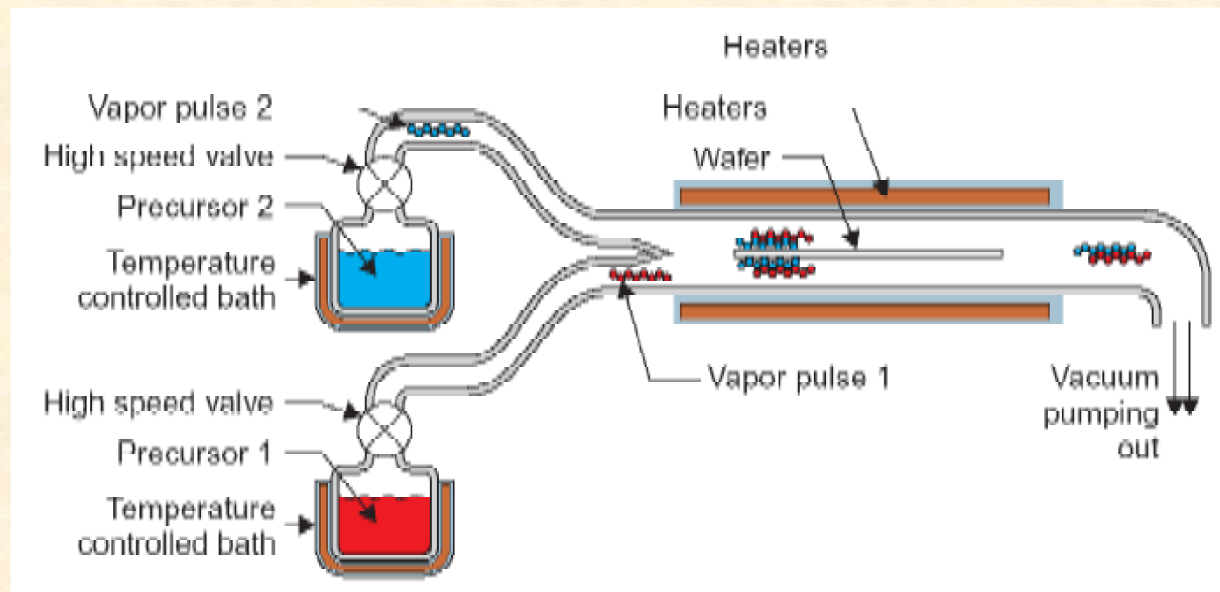
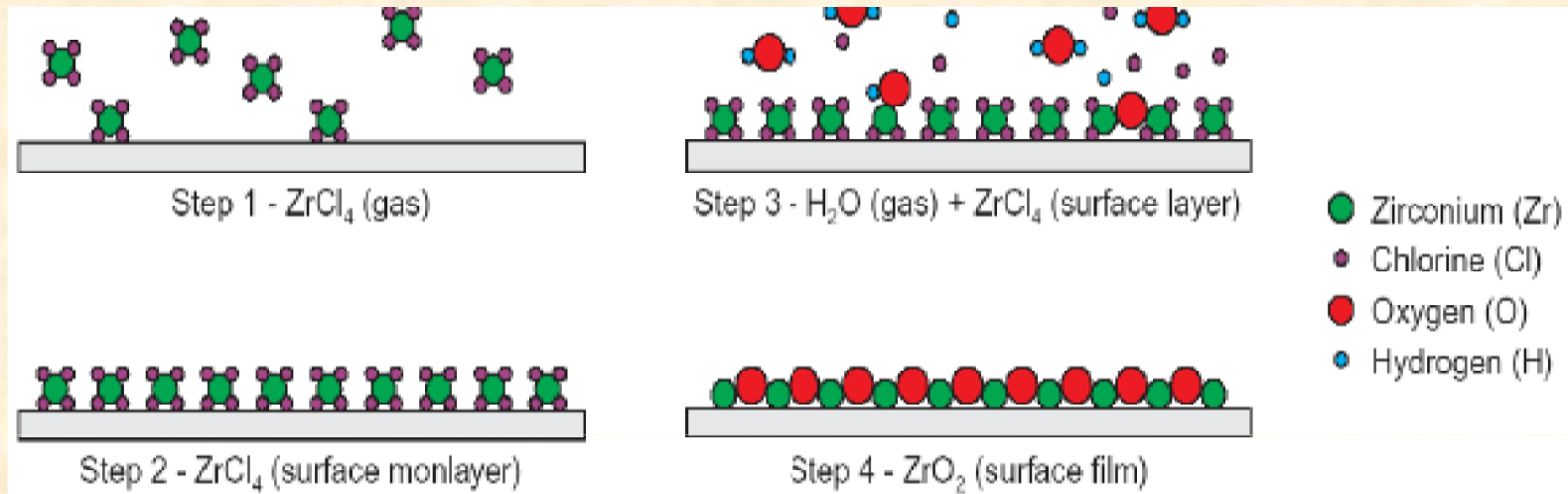

Methods for making 0-D Nanomaterials

- Nanoclusters are made by either gas-phase or liquid-phase processes.
- The commonest of which are inert-gas condensation and inert-gas expansion.
- Liquid phase processes use surface forces to create nanoscale particles and structures. There are broad types of these processes: ultrasonic dispersion, sol-gel methods, and methods relying on self-assembly.

Nanoparticle condensation in inert gas

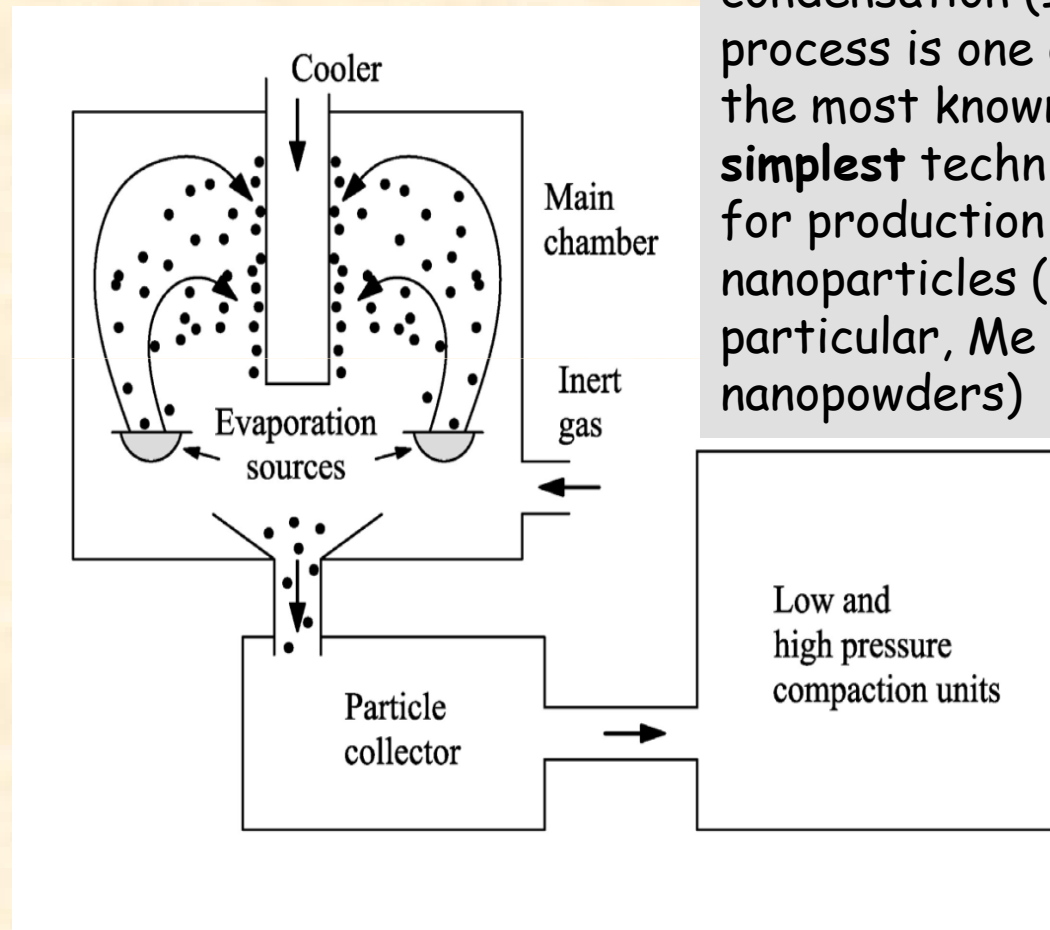

The inert gas condensation (IGC) process is one of the most known and **simplest** technique for production of nanoparticles (in particular, Me nanopowders)

An inorganic material is **vaporized** inside a **vacuum** chamber into which an **inert** gas (typically argon or helium) is periodically admitted.

Once the atoms boil off, they quickly lose their energy by colliding with the inert gas.

The vapor cools rapidly and **supersaturates** to form nanoparticles with sizes in the range 2-100 nm that collect on a finger cooled by liquid nitrogen.

Nanoparticle condensation in inert gas

A material, often a metal, is evaporated from a heated metallic source into a chamber which has been previously evacuated to about 10^{-7} torr and backfilled with inert gas to a low-pressure.

The metal vapor cools through collisions with the inert gas atoms, becomes supersaturated and then nucleates homogeneously; the particle size is usually in the range 1-100 nm and can be controlled by varying the inert gas pressure.

Ultimately, the particles are collected and may be compacted to produce a dense nanomaterial.

Example of nanoparticles obtained by IGC

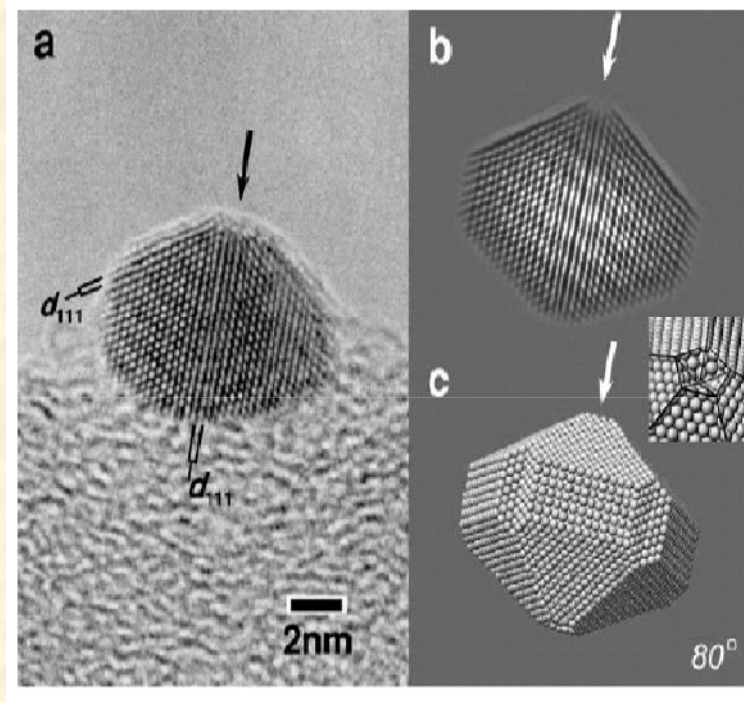

Decahedral gold nanoparticle generated from an inert gas aggregation source using helium and deposited on amorphous carbon film

[K. Koga, K. Sugawara, Surf. Sci. 529 (2003) 23]

Icosahedral gold nanoparticles generated from an inert gas aggregation source using helium and deposited on amorphous carbon film

[K. Koga, K. Sugawara, Surf. Sci. 529 (2003)

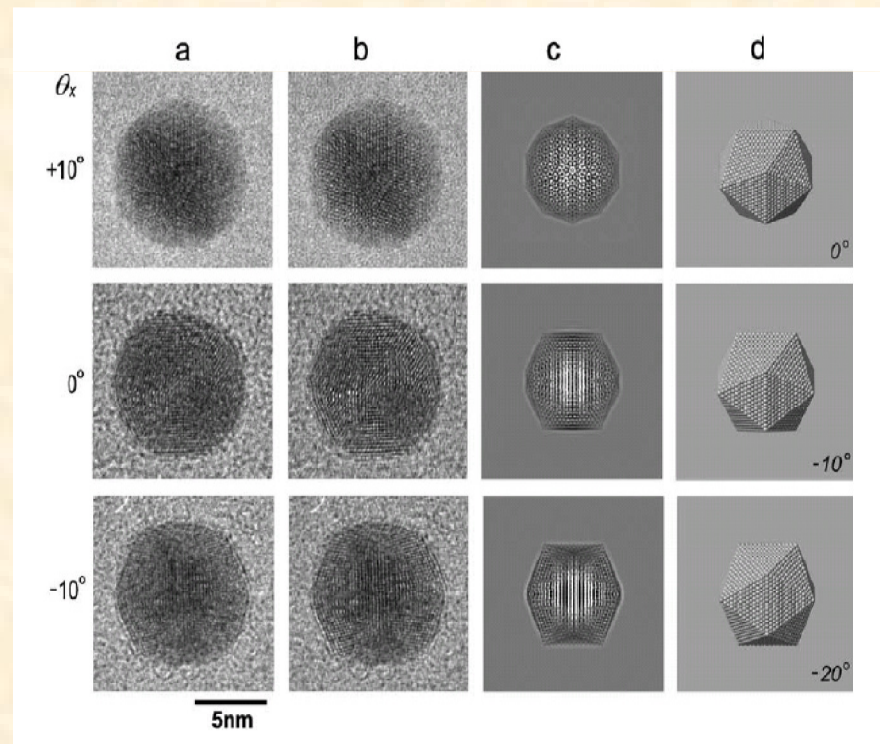

Plasma – based synthesis

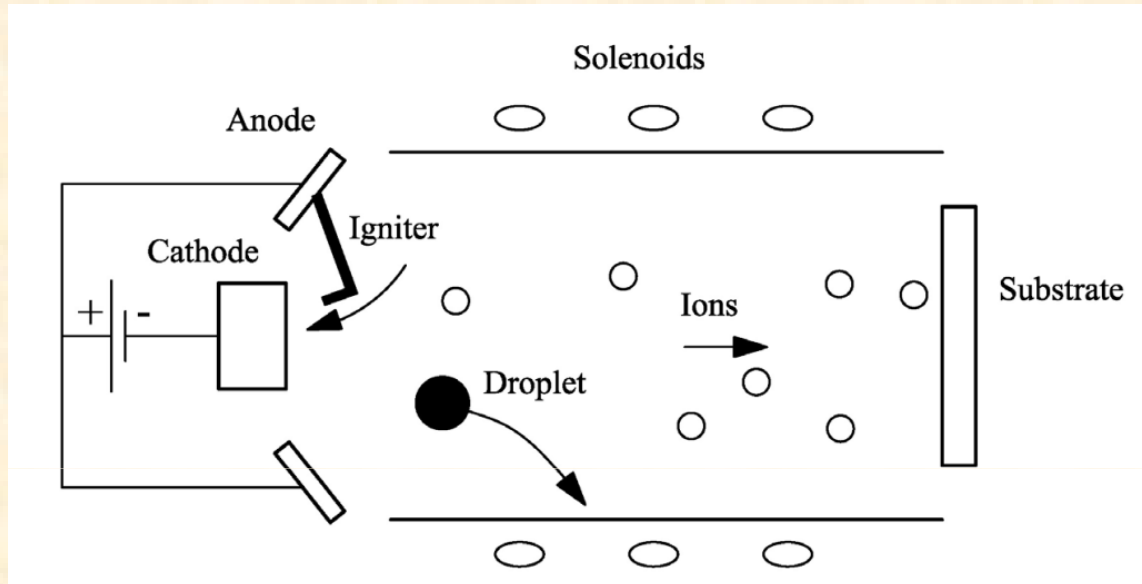

Vacuum arc deposition is well-established process for producing of thin films and nanoparticles. This technique involves the initiation of an arc by contacting a cathode made of a target material. An igniter is attached to an anode in order to generate a low-voltage, high-current self-sustaining arc.

The arc ejects ions and material droplets from a small area on the cathode. Further, the ions are accelerated towards a substrate while any large droplets are filtered out before deposition .

Vapor condensation

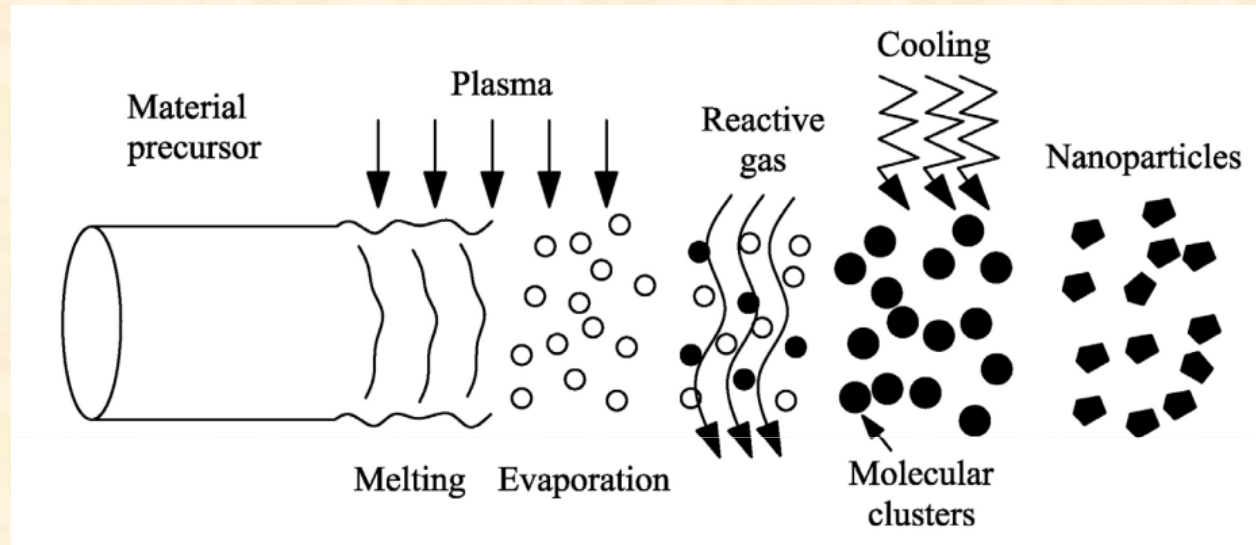

One of the outstanding strides in plasma processing for nanoparticles synthesis is the developed process of the *vapor condensation*.

The precursor material is put into the working chamber with a stable arc.

The chamber is filled by reactive gas that becomes ionized; then molecular clusters are formed and cooled to produce nanoparticles.

Methods for making 1-D and 2-D nanomaterials

- The production route for 1-D rod-like nanomaterials by liquid-phase methods is similar to that for the production of nanoparticles.
- CVD methods have been adapted to make 1-D nanotubes and nanowires. Catalyst nanoparticles are used to promote nucleation.
- Nanowires of other materials such as silicon (Si) or germanium (Ge) are grown by vapor-liquid-solid (VLS) methods.

Molecular Beam Epitaxy (MBE)



A molecular beam epitaxy (MBE) machine is essentially an ultra-high-precision, ultra clean evaporator, combined with a set of in-situ tools, such as Auger electron spectroscopy (AES) and/or reflection high-energy electron diffraction (RHEED), for characterization of the deposited layers during growth.

Molecular Beam Epitaxy (MBE)

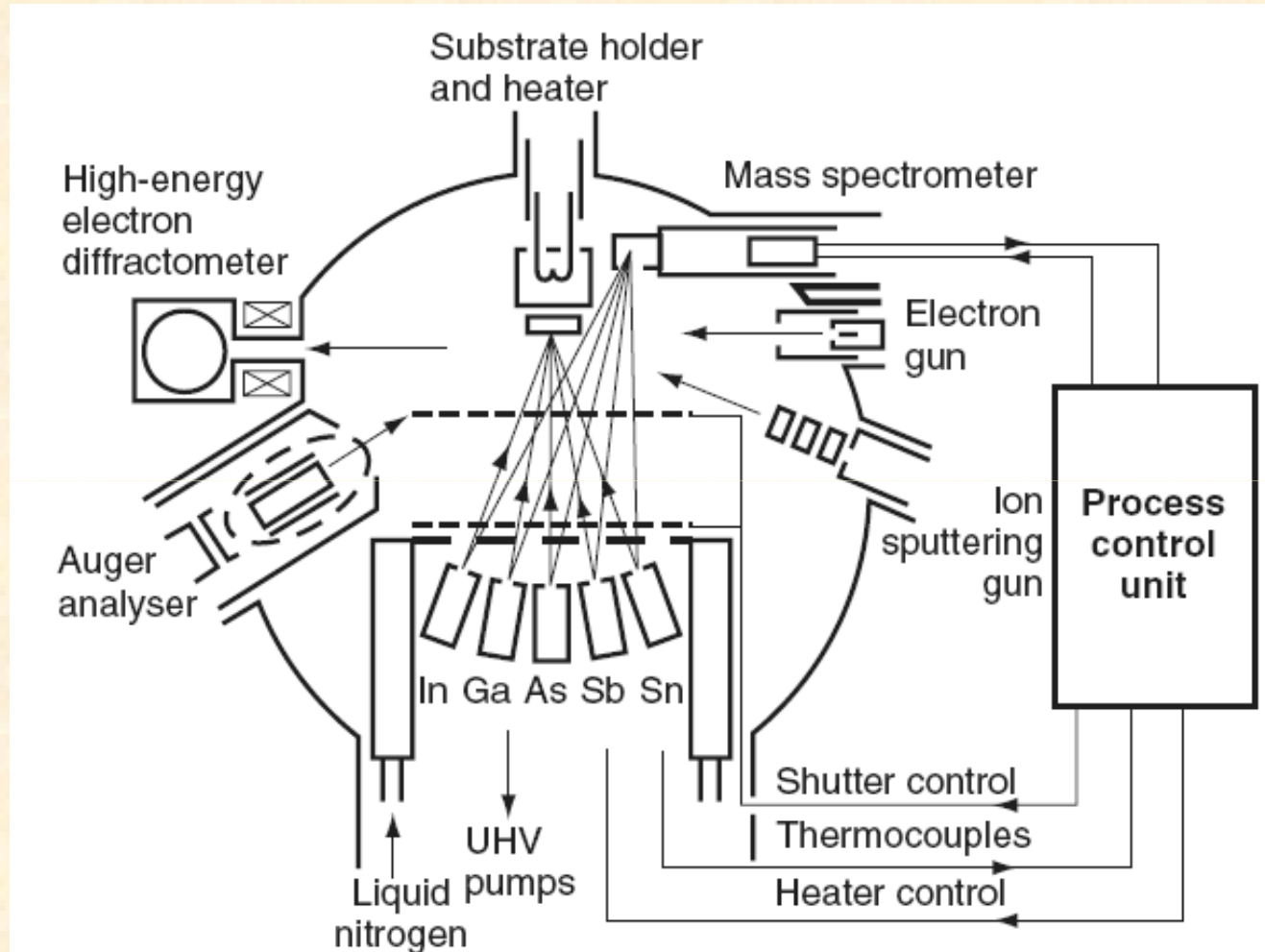

Schematic diagram of a molecular beam epitaxy thin film deposition system (adapted from *Nanoscale Science and Technology*, Eds. R.W. Kelsall, I.W. Hamley, M. Peoghegan, John Wiley&Sons Ltd, 2005).

Molecular Beam Epitaxy

In solid-source MBE, ultra-pure elements such as gallium and arsenic are heated in separate quasi-Knudsen effusion cells until they begin to slowly evaporate.

The evaporated elements then condense on the wafer, where they may react with each other. In the example of gallium and arsenic, single-crystal gallium arsenide is formed.

The term "beam" simply means that evaporated atoms do not interact with each other or any other vacuum chamber gases until they reach the wafer, due to the long mean free paths of the beams.

The substrate is rotated to ensure even growth over its surface.

By operating mechanical shutters in front of the cells, it is possible to control which semiconductor or metal is deposited.



MBE principal

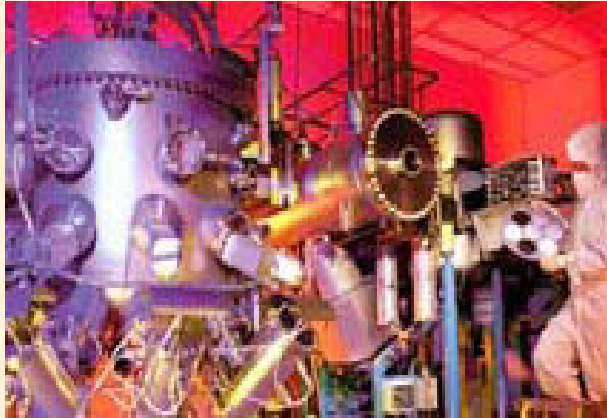

Slow but well controlled deposition rate 1 to 300 nm per minute

For example, opening the Ga and As cell shutters results in the growth of GaAs. Shutting the Ga cell and opening the Al cell switches the growth to AlAs. As the shutters can be switched rapidly, in comparison to the rate at which material is deposited, it is possible to grow very thin layers exhibiting very sharp interfaces.

32

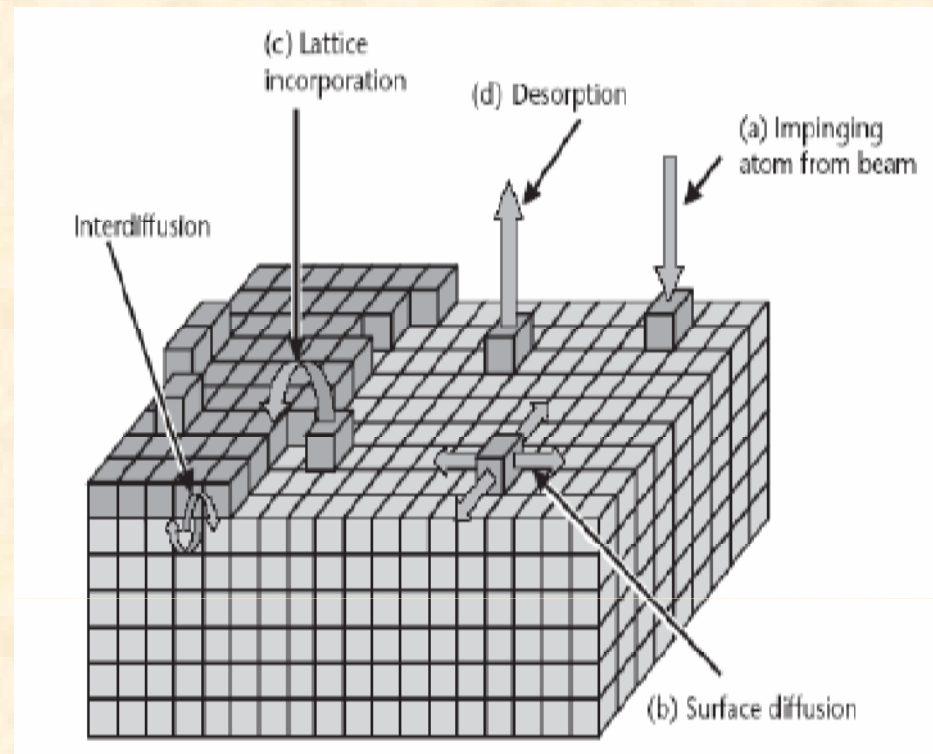

The sources can be either solid or gaseous and an MBE machine will typically have an array of multiple sources, which can be shuttered to allow layered, alternating heterostructures to be produced. Semiconductor quantum wells, superlattices and quantum wires and metallic or magnetic multilayers for spin valve structures are deposited using this technique.

Metal-organic Chemical Vapor Deposition (MOCVD)



Schematics of the commercial MOCVD system

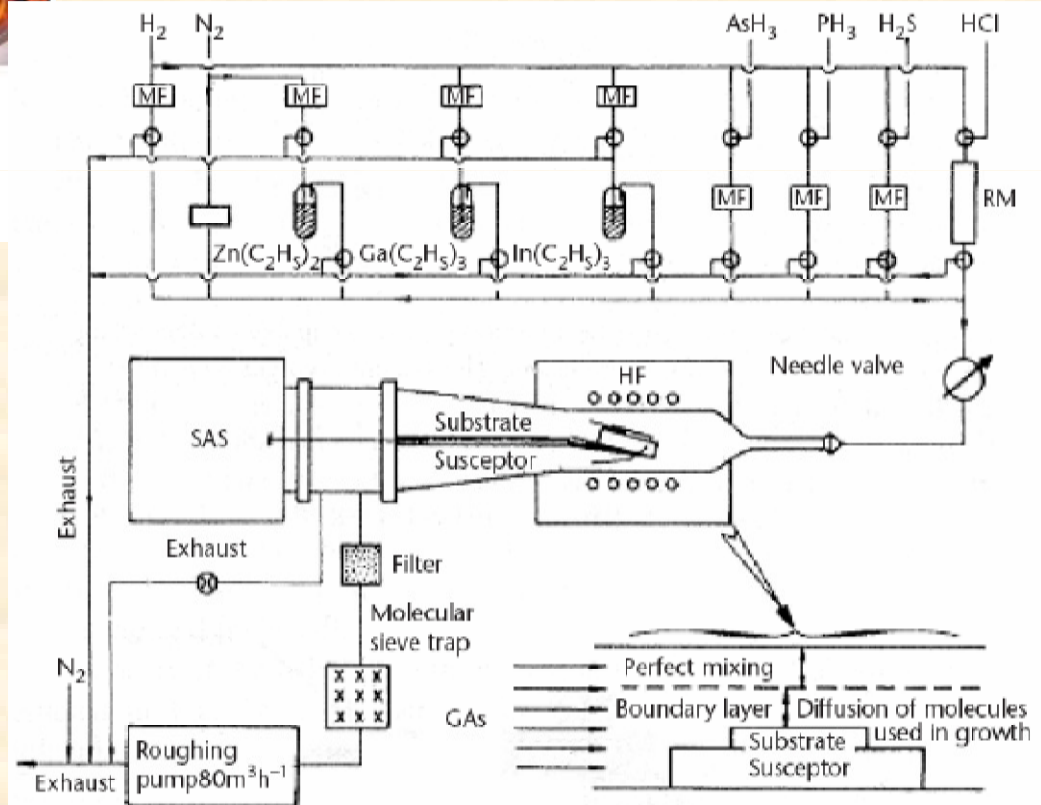

Electrodeposition

- **Electrodeposition** is a long-established way to deposit metal layers on a conducting substrate.
- Ions in solution are deposited onto the negatively charged cathode, carrying charge at a rate that is measured as a current in the external circuit.
- The process is relatively **cheap** and **fast** and allows **complex** shapes.
- The layer thickness simply depends on the current density and the time for which the current flows.
- The deposit can be detached if the substrate is chosen to be soluble by dissolving it away.

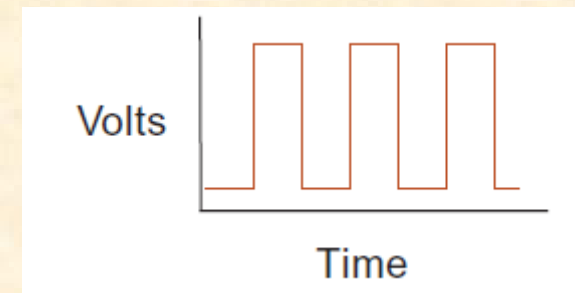
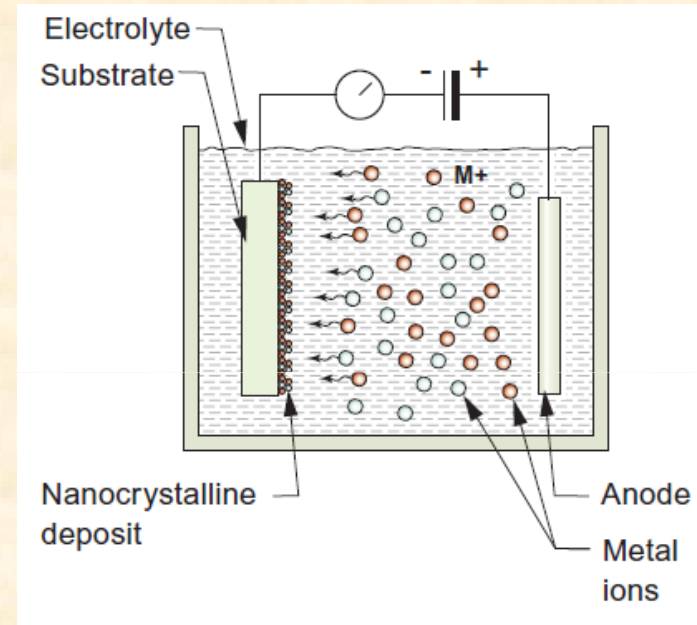

Electrodeposition - basics

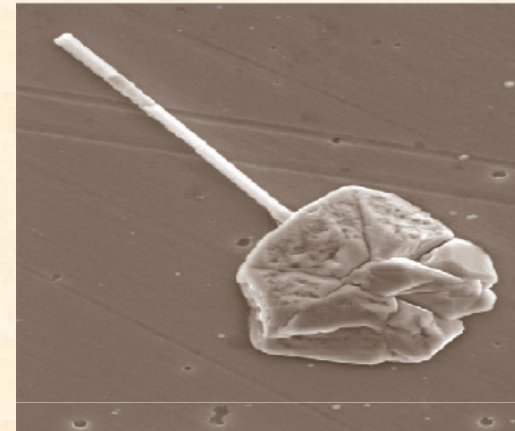
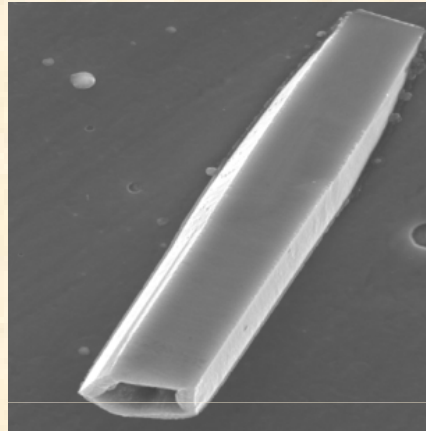
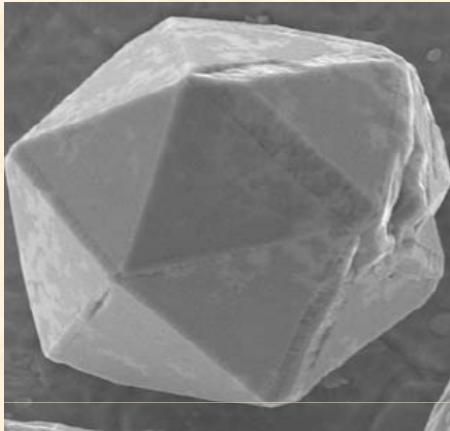

Icosahedral microparticles, pentagonal microtubes and whiskers obtained in the process of copper electrodeposition [after A.A. Vikarchuk]

The principle of electrodeposition is inducing chemical reactions in an aqueous electrolyte solution with the help of applied voltage, e.g. this is the process of using electrical current to coat an electrically conductive object with a relatively thin layer of metal. This method is relevant to deposition of nanostructured materials include metal oxides and chalcogenides.

Electrodeposition - features

Electrodeposition is relatively cheap and can be performed at low temperatures which will minimize interdiffusion of materials in the case of a multilayered thin film preparation.

The **film thickness** can be controlled by monitoring the amount of charge delivered, whereas the deposition rate can be followed by the variation of the current with time.

The **composition and defect chemistry** can be controlled by the magnitude of the applied potential, which can be used to deposit non-equilibrium phases. Pulsing or cycling the applied current or potential in a solution containing a mixture of precursors allows the production of a multilayered material.

The potential during the pulse will determine the species deposited whilst the thickness of individual layers is determined by the charge passed. Alternatively, the substrate can be transferred periodically from one electrolytic cell to another.

The final films can range in thickness from a few nanometers to tens of microns and can be deposited onto large specimen areas of complex

Electrodeposition and microelectronics

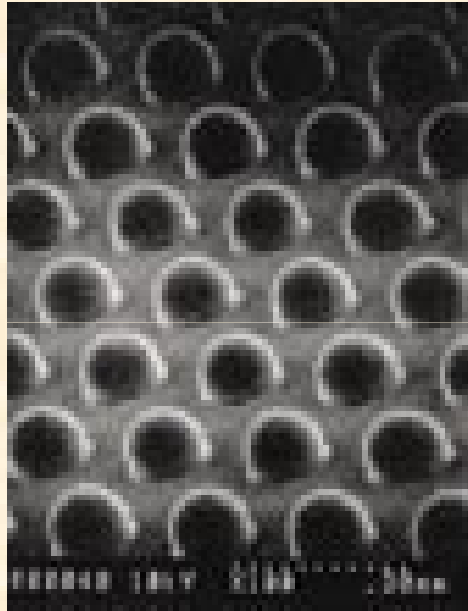

Electrochemically fabricated flip-chip interconnects

Electrodeposition (ED) is being exploited now to make complex 3D electrical interconnects in computer chips. The **key concept** is that electrodeposited materials grow from the conductive substrate outward, and the geometry of the growth can be controlled using an insulating mask (so-called through mask electrodeposition).

Electrodeposition in microelectronics

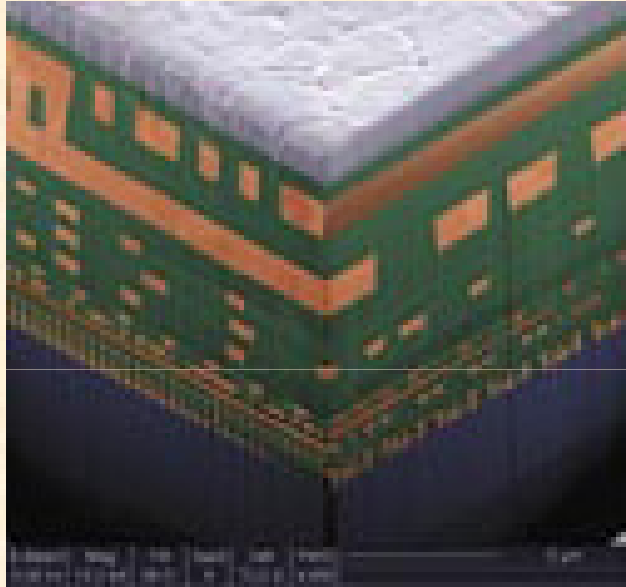

A ten level copper on-chip interconnect scheme of 90 nm CMOS node fabricated in low dielectric constant material.

The insulating mask need not have a straight line-of-sight path between the substrate and the electrolyte; even tortuous masks can be filled with materials, so long as the whole path through the mask is wetted with the ED electrolyte.

The resulting deposit is a high fidelity negative replica of the mask itself. Through-mask ED has been used extensively to pattern metals, semiconductors, and polymers on conductive substrates.

Electrodeposition and nanobiosystems

As a water-based process, it is often more *environmentally friendly* than deposition methods that require hazardous solvents and reactive precursor chemicals (like organometallic compounds, for instance).

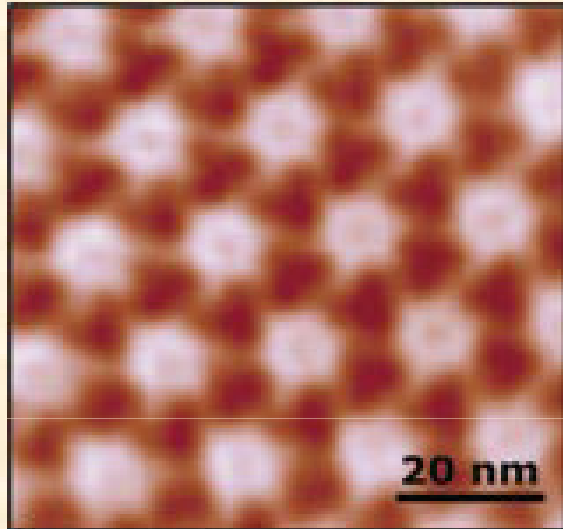

Nanometer-scale cuprous oxide (colorized red) can be electrodeposited through the openings in the hexagonally packed intermediate layer protein (white regions) from the bacterium *Deinococcus radiodurans*. Purified crystalline protein sheets are first adsorbed to a conductive substrate, and then electrodeposition is carried out to fill the nanometer-scale pores in the protein.

Biological fabrication.

Proteins are responsible for the nucleation, growth, composition, and shape of functional biological structures like bones, teeth, and shells. Using proteins to control the growth of ED materials is **truly a frontier area where biology meets nanotechnology.**

One way that proteins are being used in electrochemical nanotechnology is as masks for through mask electrodeposition.

Proteins can self-organize into complex structures representing all possible two-dimensional (2D) space groups built from chiral molecules. Moreover, they are readily engineered through molecular biology, providing an attractive foundation for nanotechnology.

Why electrodeposition?



*Miniature copper mask from the site of Loma Negra on the far north coast of Peru, ca. 200 C.E. Removal of the green copper corrosion products reveals a bright gold surface. The extremely thin layer of gold was applied to the sheet copper by electrochemical replacement plating.
[Heather Lechtman, *Sci. Amer.*, 250(6), 56 (1984).]*

Electrodeposition has **three main attributes** that make it so well suited for **nano-, bio- and microtechnologies.**

- It can be used to grow functional material through complex 3D masks.
- It can be performed near room temperature from water-based electrolytes.
- It can be scaled down to the deposition of a few atoms or up to large dimensions.